

# COMPACT 24" 4 SHAFTS 1022-0000



1972 Avenue Simoneau  
C. P. 4  
Plessisville, Qc.  
G6L 2Y6

TEL: 819-362-7207  
FAX: 819-362-2045

[www.leclerclooms.com](http://www.leclerclooms.com)  
[leclerc@leclerclooms.com](mailto:leclerc@leclerclooms.com)



On receiving the loom, unpack and lay out the loom components. Do NOT discard any packing material until all parts are inventoried.

Check the parts received against the parts list on pages #2 to #6 of the assembly instructions. Report any discrepancies to Leclerc immediately.

To assemble this loom, a minimum of 2 people are needed but it is recommended you use 3.

# PARTS AS SHIPPED

1 frame with shafts

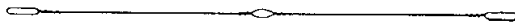
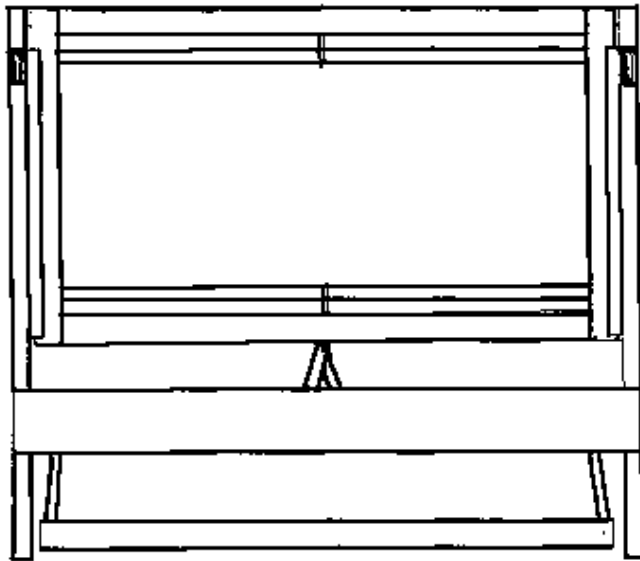

10½"

600 heddles 10½"



1 threading hook



1 multi bits screwdriver

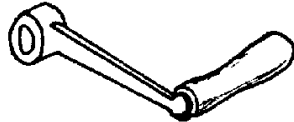

1 crank (Octagonal)



12 treadle cords 9"



1 - 5 yard cord  
2 - 10 yard cords



1 boat shuttle (6122-1000)



1 aluminum wrench



1 adjustable wrench

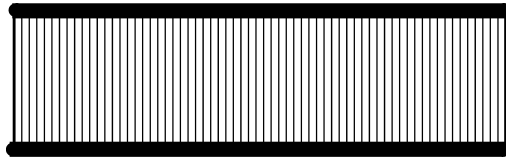

1 reed

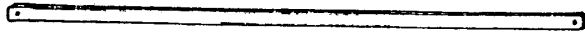

2 lease sticks 25" (metal)

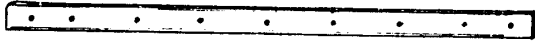

2 beam sticks 24½" (metal)

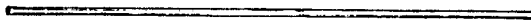

2 warp rods (metal)

1 right hand side front post (with  
brake flat metal circle)  
44"

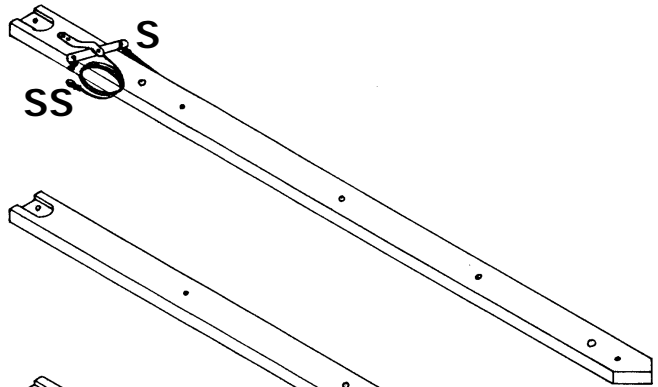

1 left hand side rear post 44"

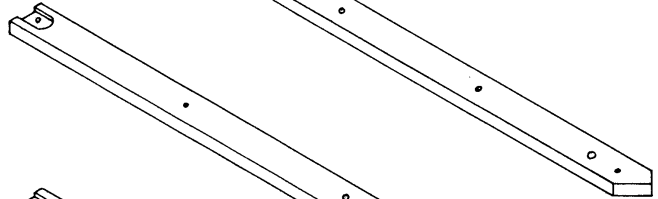

1 left hand side front post 44"

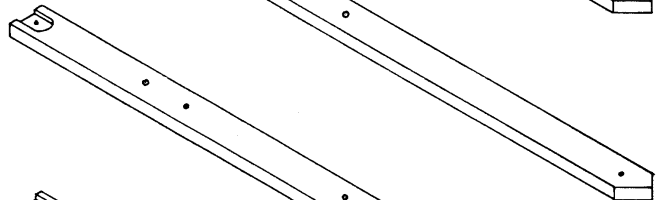

1 right hand side rear post 44"

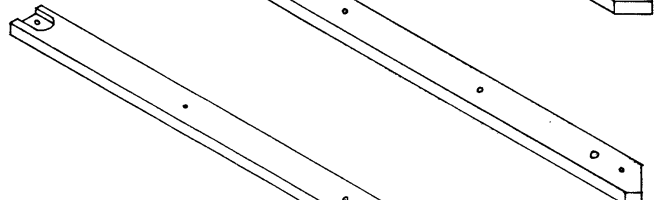

1 lower rear cross-member 30½"

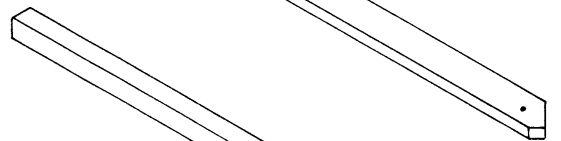

1 treadle cross-member 29"

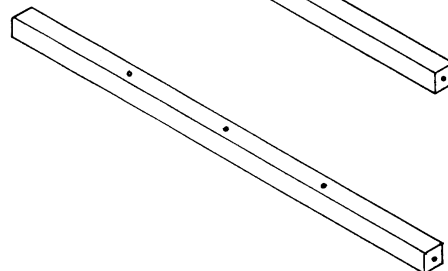

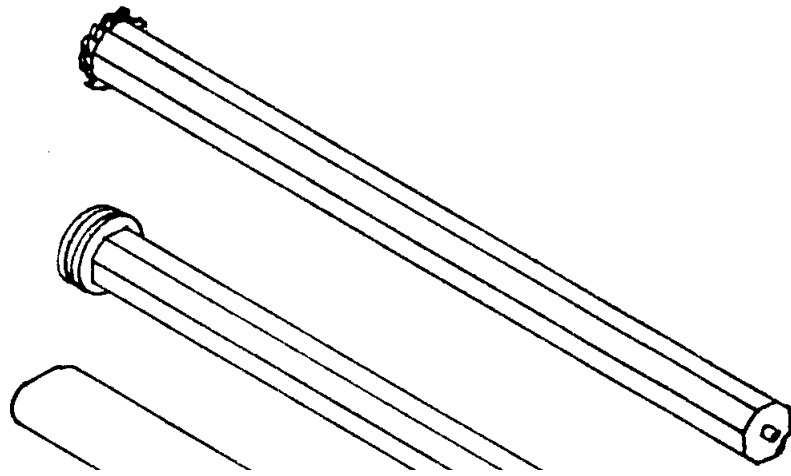

1 cloth beam 25"

1 warp beam 28 9/16"



1 thread beam 31"

4 side post  
iron fittings

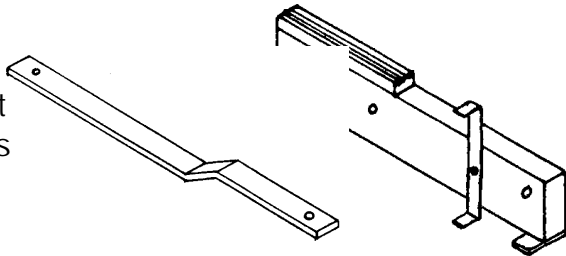

1 right hand side support with  
ratchet pawl 10 1/2"

1 take-up  
motion handle

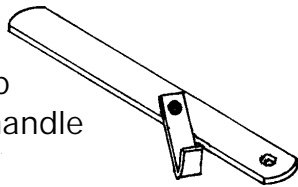

3 treadle blocks

2 Wood pegs 1/2" x 1 3/4"

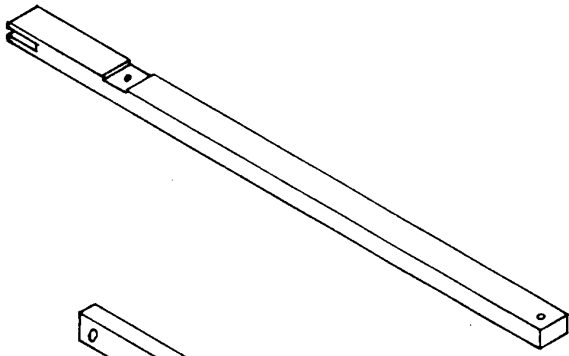

2 batten swords 27¼"

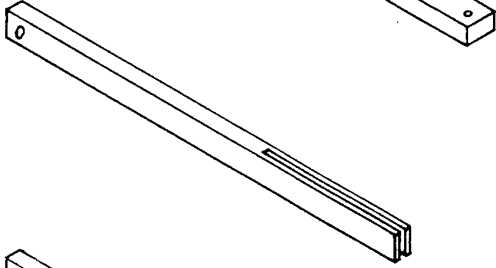

6 treadles 20"

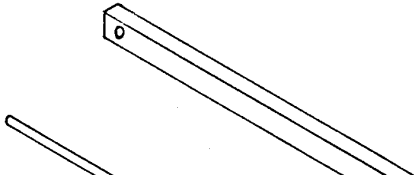

1 brake treadle 20"

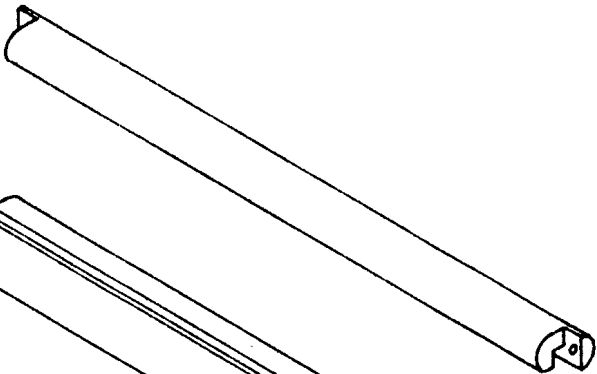

1 treadle rod 5/16" x 30"

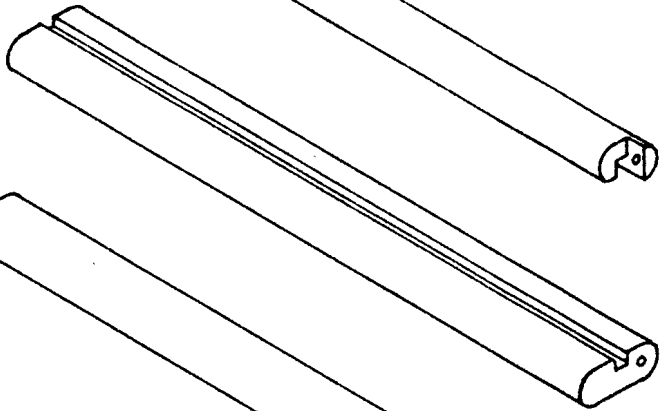

1 batten handtree 29"

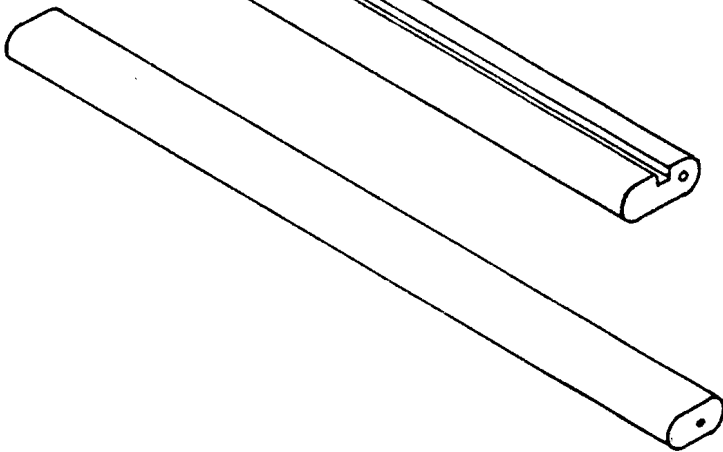

1 batten sley 27¾"



1 breast beam 29½"

# PARTS LIST

**NYLON NUTS**  

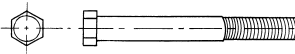
 4X - Nylon auto lock 5/16" (8mm)

**Machine bolts**  
 1X - 5/16" x 3"  
 8mm x 75mm



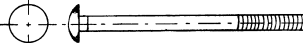

**Wing nuts**  
  
  
 2 X - 1/4" (6 mm)

**Carriage Bolts**  
  
 2X - 1/4" x 2 1/2" (6mm x 65mm)  
 2X - 5/16 x 2 3/4" (8mm x 70mm)  
 2X - 5/16" x 2" (8mm x 50mm)

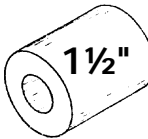

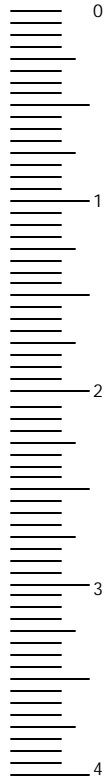
**Washers**  
 4X - 3/16" (5mm)  
 6X - 5/16" (8mm)  
 2X - 1/4" (6mm)

**Wooden spacer**  
 1 1/2"  
 4X wood spacers



 2 plastic spacers

 2 handles

**Round head screw**  
  
  
 9X - #14 x 2" (50mm)  
 8X - #14 x 1 1/2" (40 mm)  
 4X - #12 x 3/4" (20mm)

 2 push nuts 5/16" for treadle rod.

 1 VHS instruction Video



1 loop cord for brake 24"



1 book Warp&Weave

Lay down the frame (the bumpers must be on top) and pull on the lams C until the jacks D are parallel with the lams.

Insert the left support E into the left end of the cloth beam F, then insert the take-up motion handle G and the right support H, into the right side of the cloth beam. Push all these parts between the sides of the loom and fix each support with two 1½" (40mm) round-headed screws No. 14.

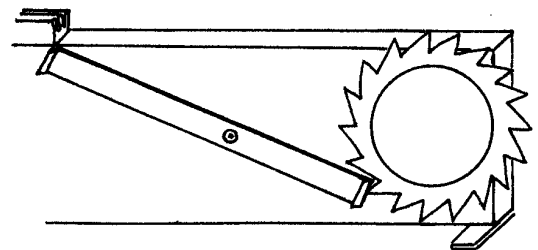
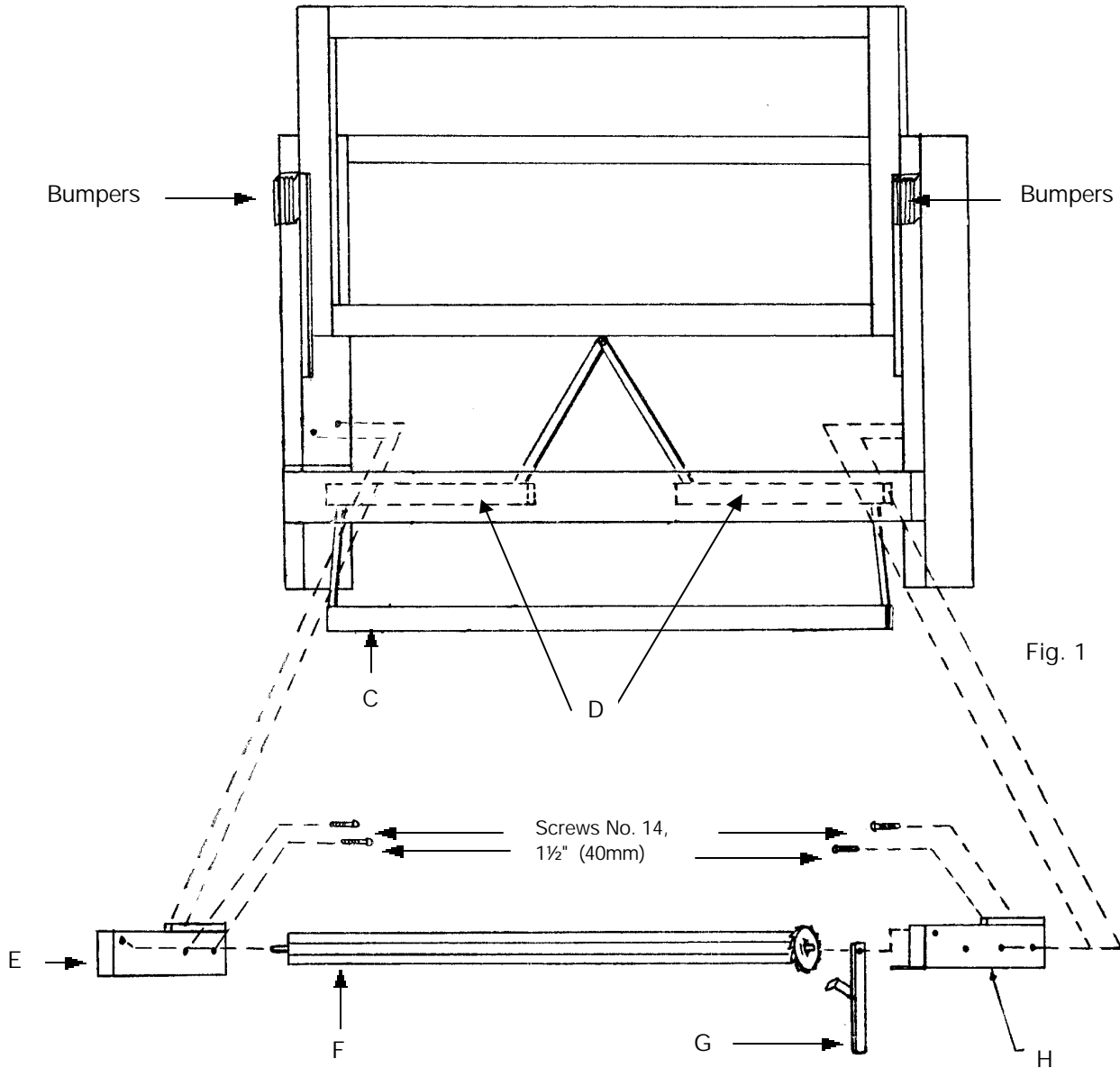

Make sure that the ratchet pawl is in the correct position.

Fix an iron fitting A on each of the 4 legs . Make sure they are positioned exactly as show in the diagram below.

Put a 3/16" (5mm) steel washer between the iron fitting and the leg.

Screw them in using the 3/4" (20mm) round-headed screw No. 12. Do not over tighten so the iron can move freely.

The screw must be inserted into the smallest hole of the iron fitting.

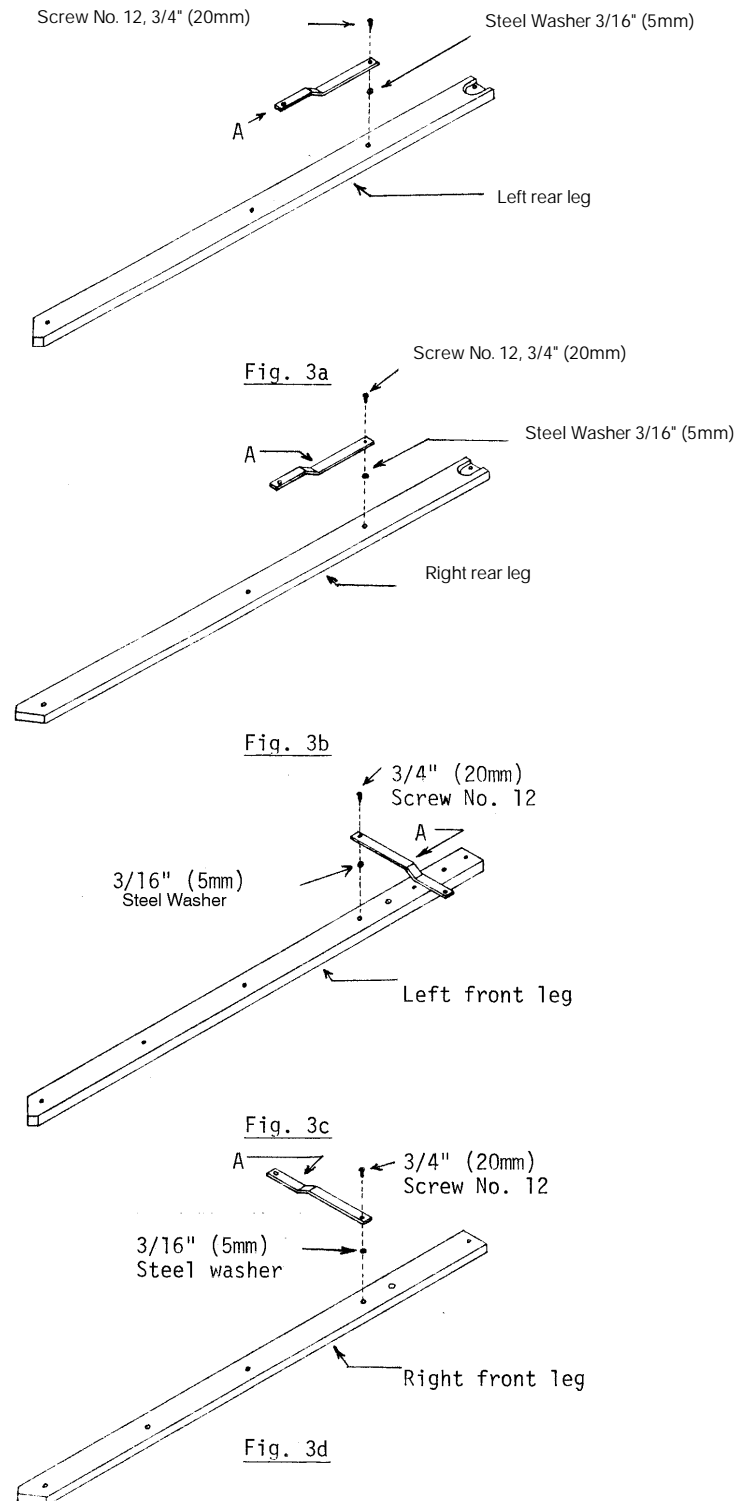



Place the loom frame on its right side. Fix the left front A and rear B legs to the left side of the frame with a 5/16" x 2 3/4" (8mm x 70mm) carriage bolt. With a hammer, hit on the head of the bolt until it is even with the leg B. Cross the legs so that the lower end of the leg B is towards the back and the lower end of the leg A is towards the front. Add a steel washer and screw a 5/16" (8mm) lock nut in without overtightening it. You must feel light resistance when you swivel the legs.

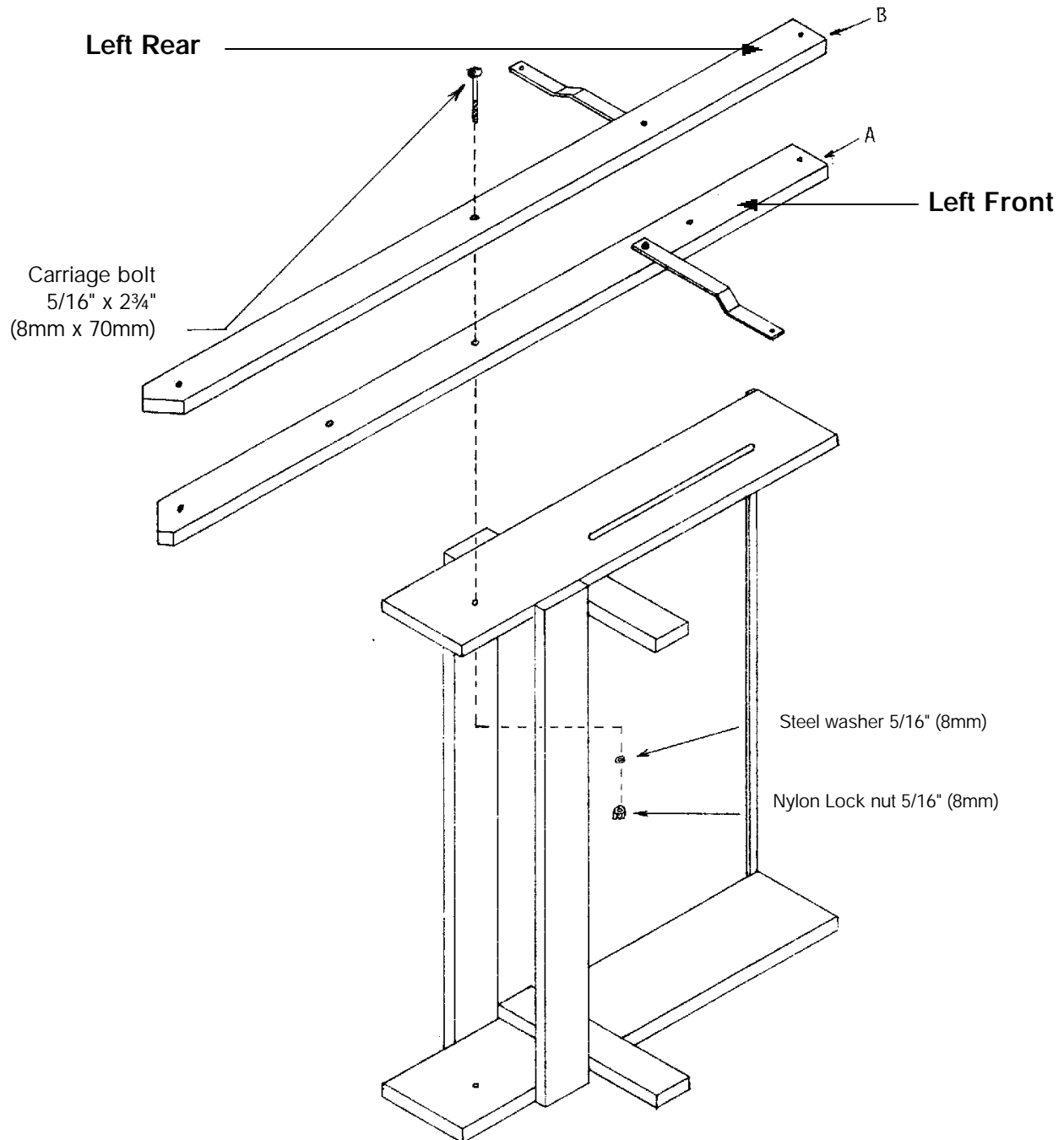

Fig. 4

Put a plastic spacer A in the groove as illustrated. Insert the threaded rod of the handle B. First into the front leg iron fitting C, then into the rear leg iron fitting D, then into the spacer A (fig 5). Screw the handle in the metallic plate E inside the groove and tighten it in the lower position.

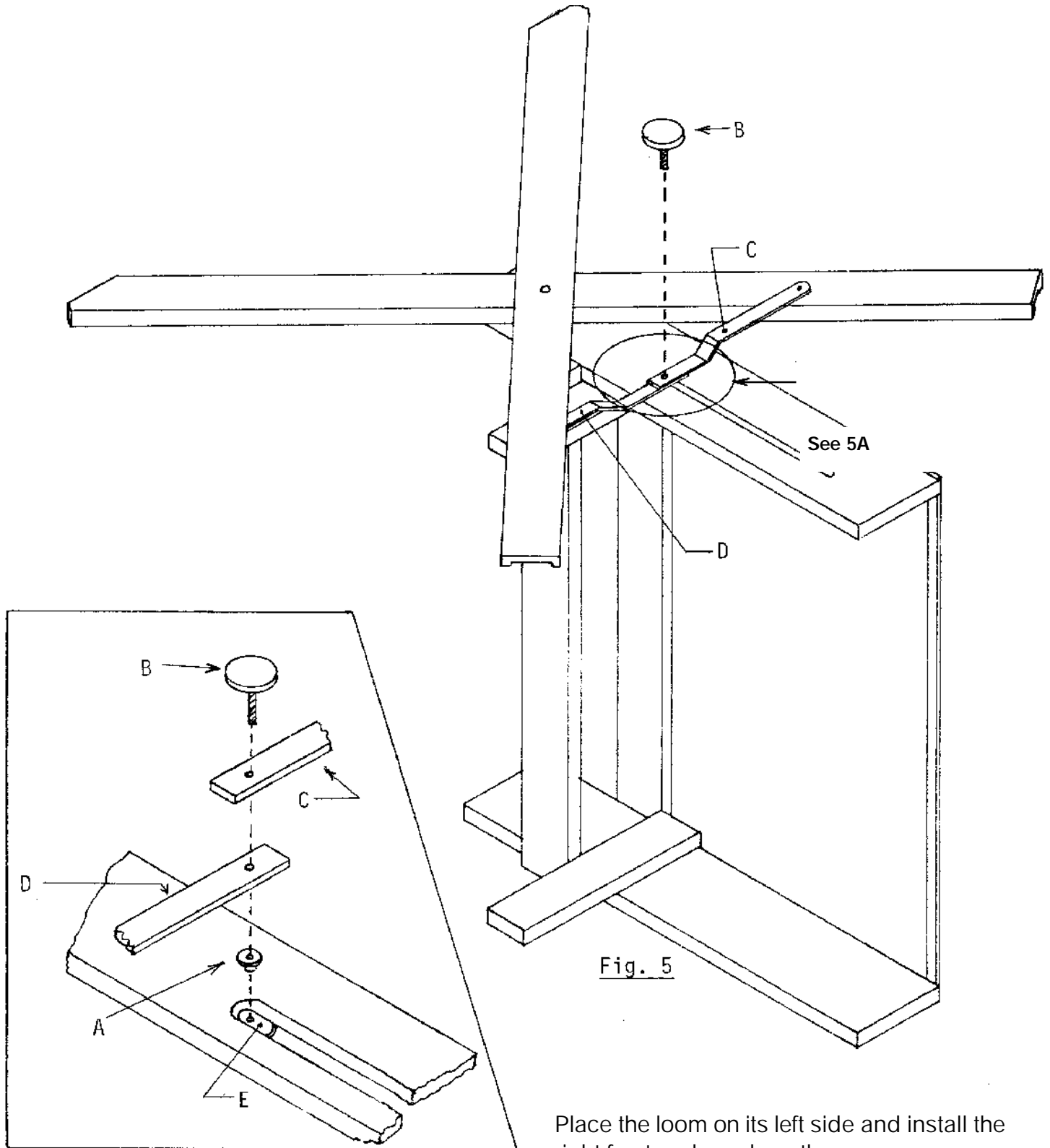
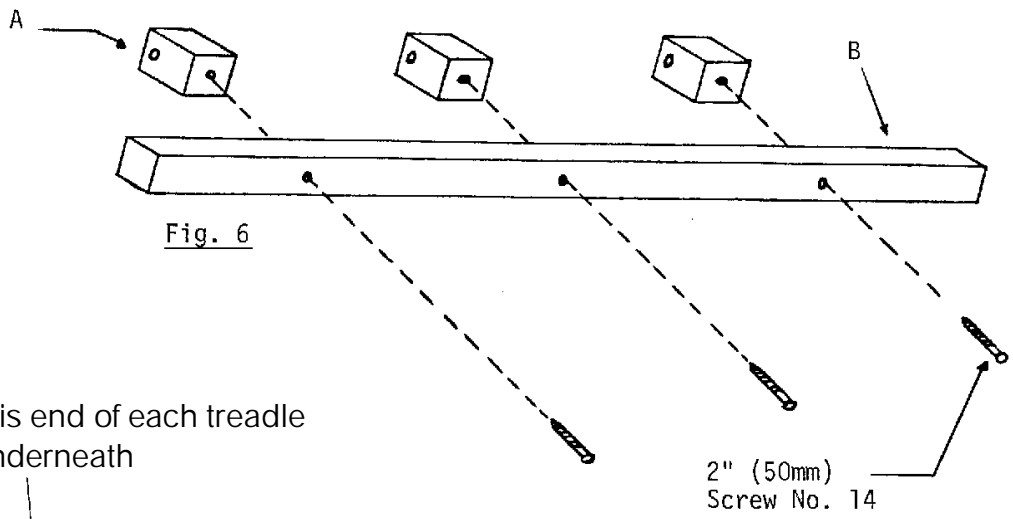

Fig. 5

Place the loom on its left side and install the right front and rear legs the same way. Place the loom on its legs.

5A

Fix the three (3) treadle blocks A to the treadle cross-member B with 2" (50mm) round-headed screws No. 14 (fig. 6).  
Note: Do not overtighten so blocks can move.



Holes at this end of each treadle must be underneath

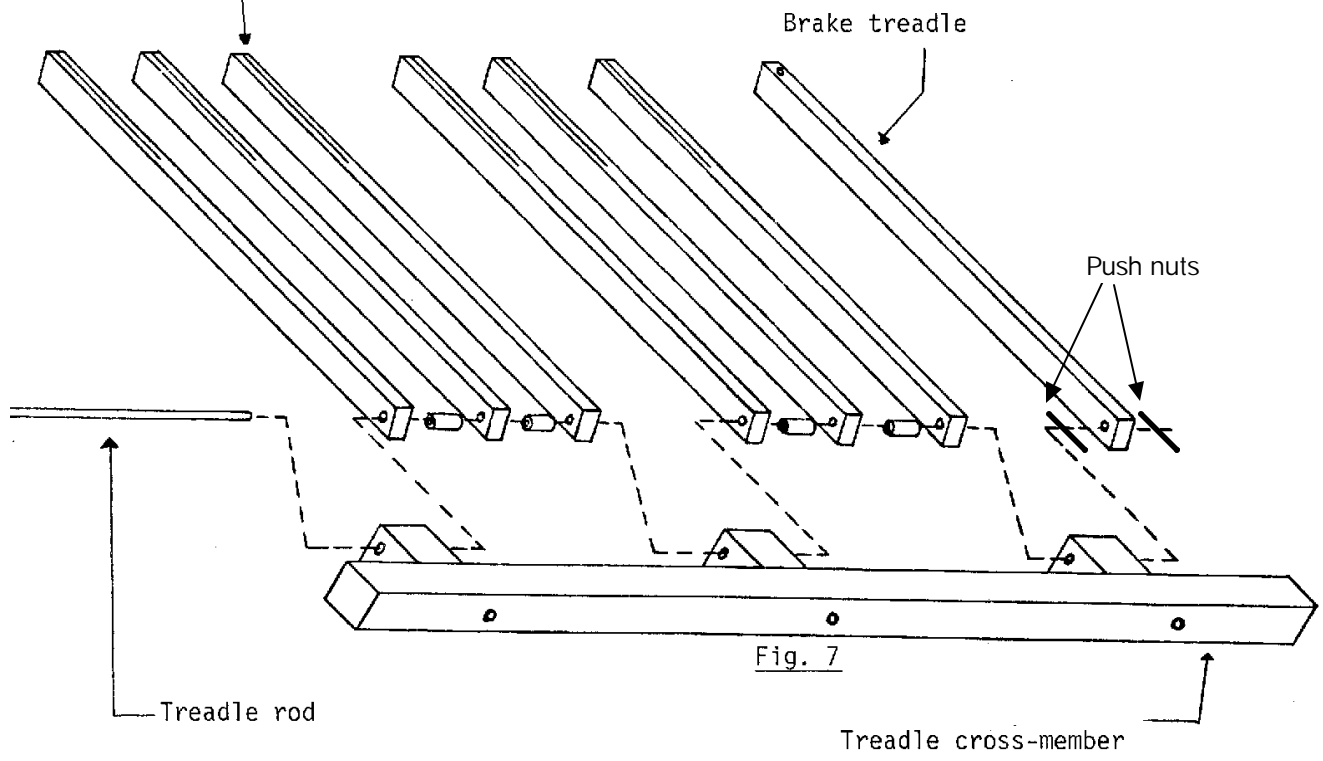

Assemble the treadle set as shown on figure 7. The brake treadle must be on the right side.  
Put one push nut on each side of the brake treadle and center it between the treadle block and the end of the treadle cross-member

Place the treadle set between the two (2) front legs by spreading them out slightly, so that the ends of the treadle rod A fit between the legs.

Fix the treadle cross-member B with two (2) (50mm) round-headed screws No. 14.

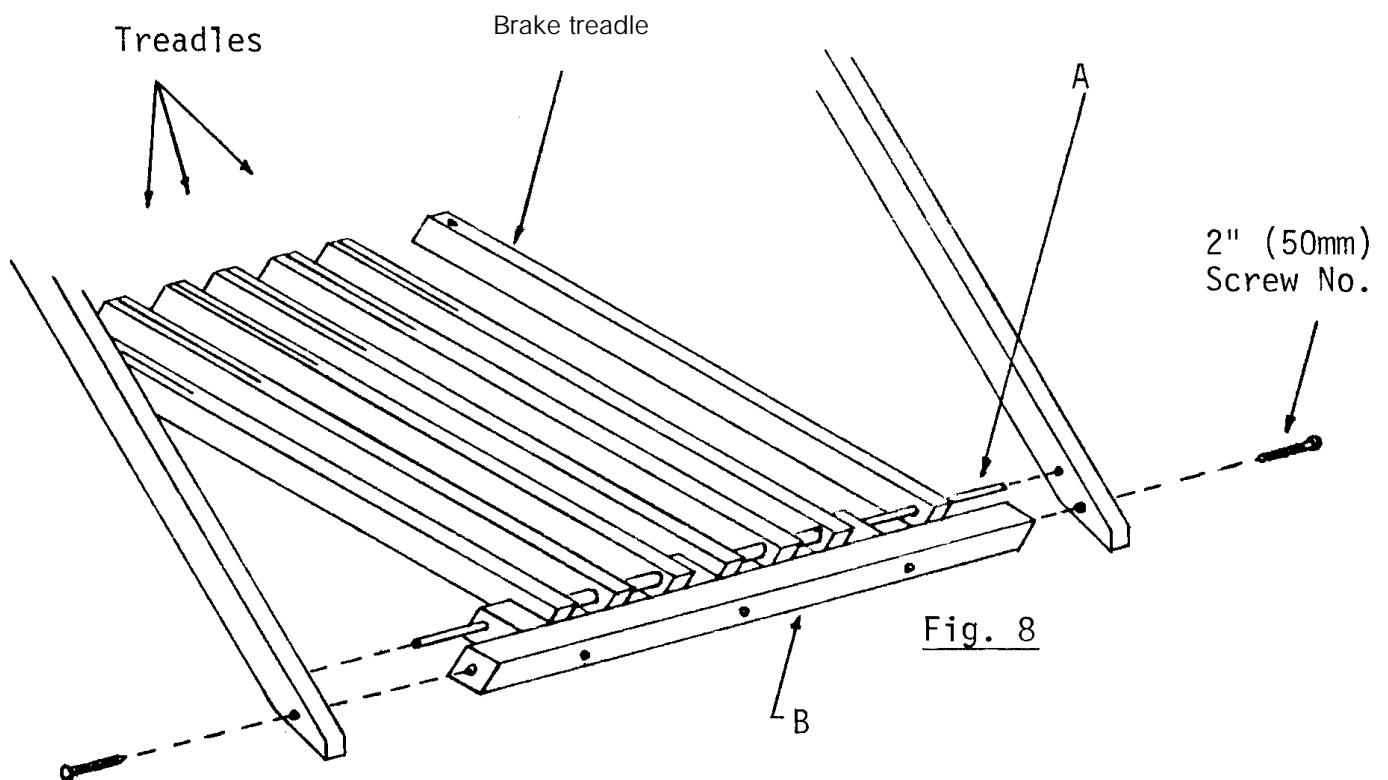

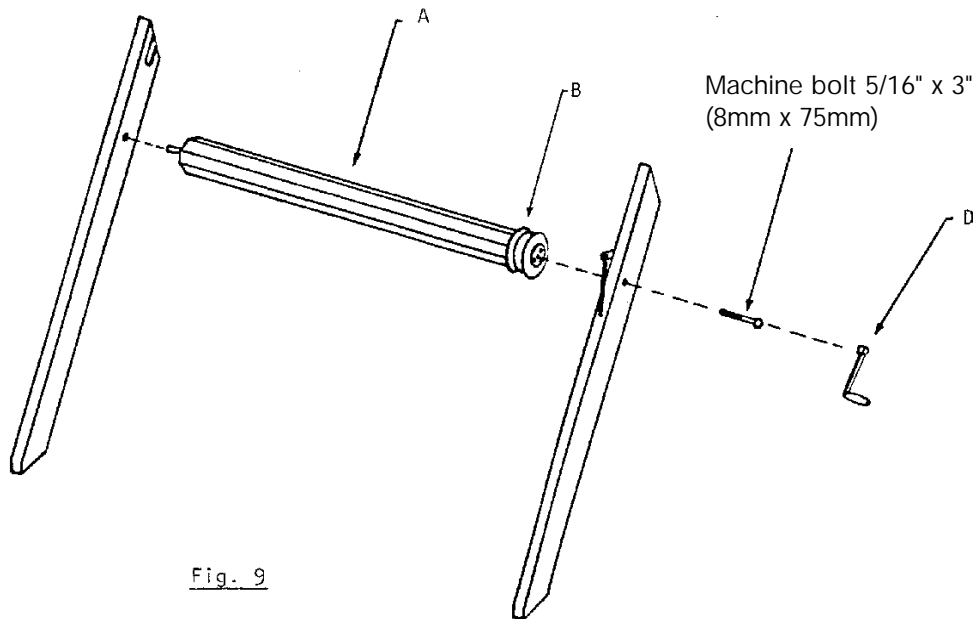

Fig. 9

Install the warp beam A between the two (2) front posts (fig. 9), taking care to insert the brake drum B into the flat metal brake circle (fig. 10)

Screw a 5/16" x 3" (8mm x 75mm) machine bolt into the brake drum B.

Use the crank D to tighten the bolt firmly. (fig. 9)

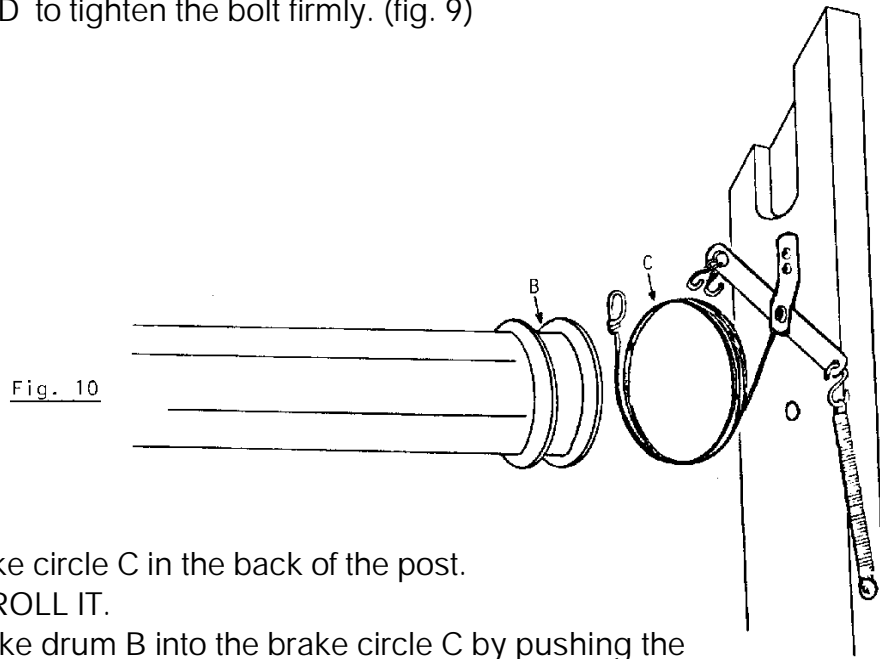

Fig. 10

Hold the brake circle C in the back of the post.

**DO NOT UNROLL IT.**

Insert the brake drum B into the brake circle C by pushing the warp beam.

Install the thread beam (29½") A using round-headed screws No. 14, 1½". Install the lower cross-member B (30½") in back of the loom with round-headed screws No. 14, 2".

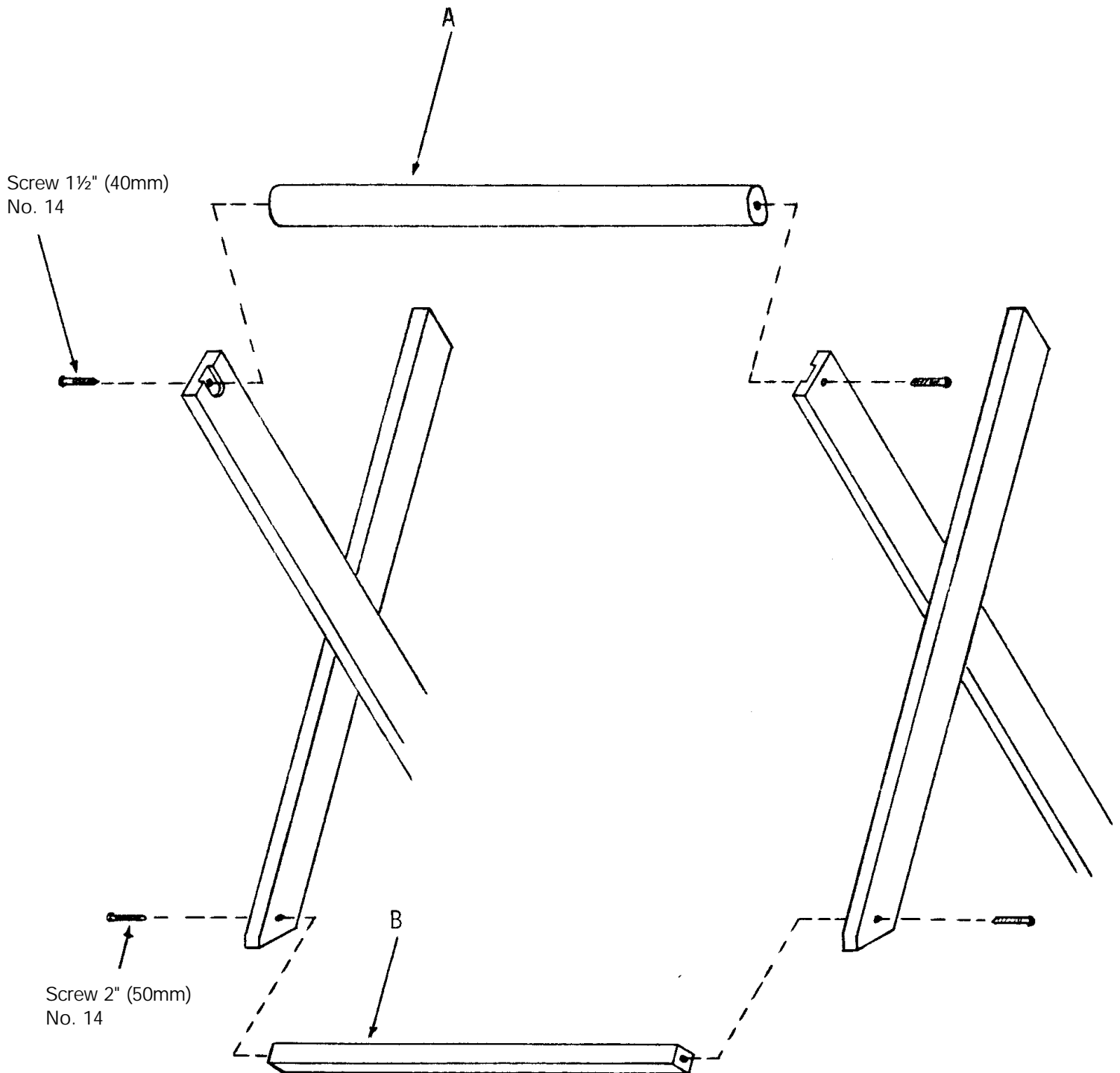

Fig. 11

Fix each of the two (2) batten swords A inside the front legs with a 5/16" x 2" (8mm x 50mm) carriage bolt.

Place a steel washer between the sword and the leg. With a hammer, hit on the head of the bolt until the square inside part is in the wood. Put a washer inside and lock it with the nylon auto lock nut 5/16" (8mm) without overtightening it. Swords must move freely.

Fix the batten sley B with two 2" (50mm) round-headed screws No. 14.

Fix the batten handtree C with two 1/4" x 2 1/2" (6mm x 65mm) carriage bolts, two steel washers and two 1/4" (6mm) wing nuts.

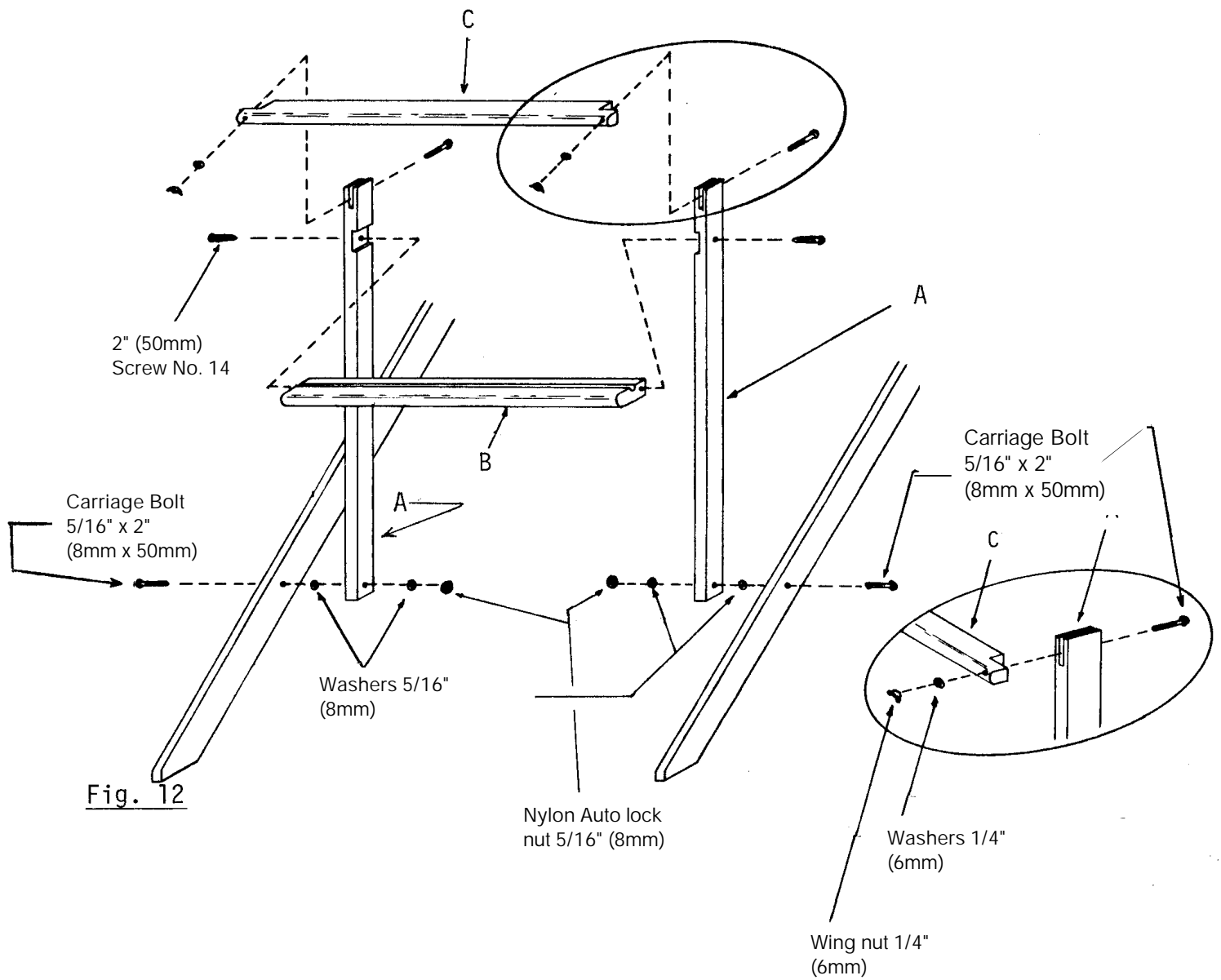

Place the reed A between the batten handtree B and the batten sley C, and lower the batten handtree.

Tighten the wing nuts.

Using a hammer, insert a batten stopper D (round piece of wood) into each of the two (2) swords E.

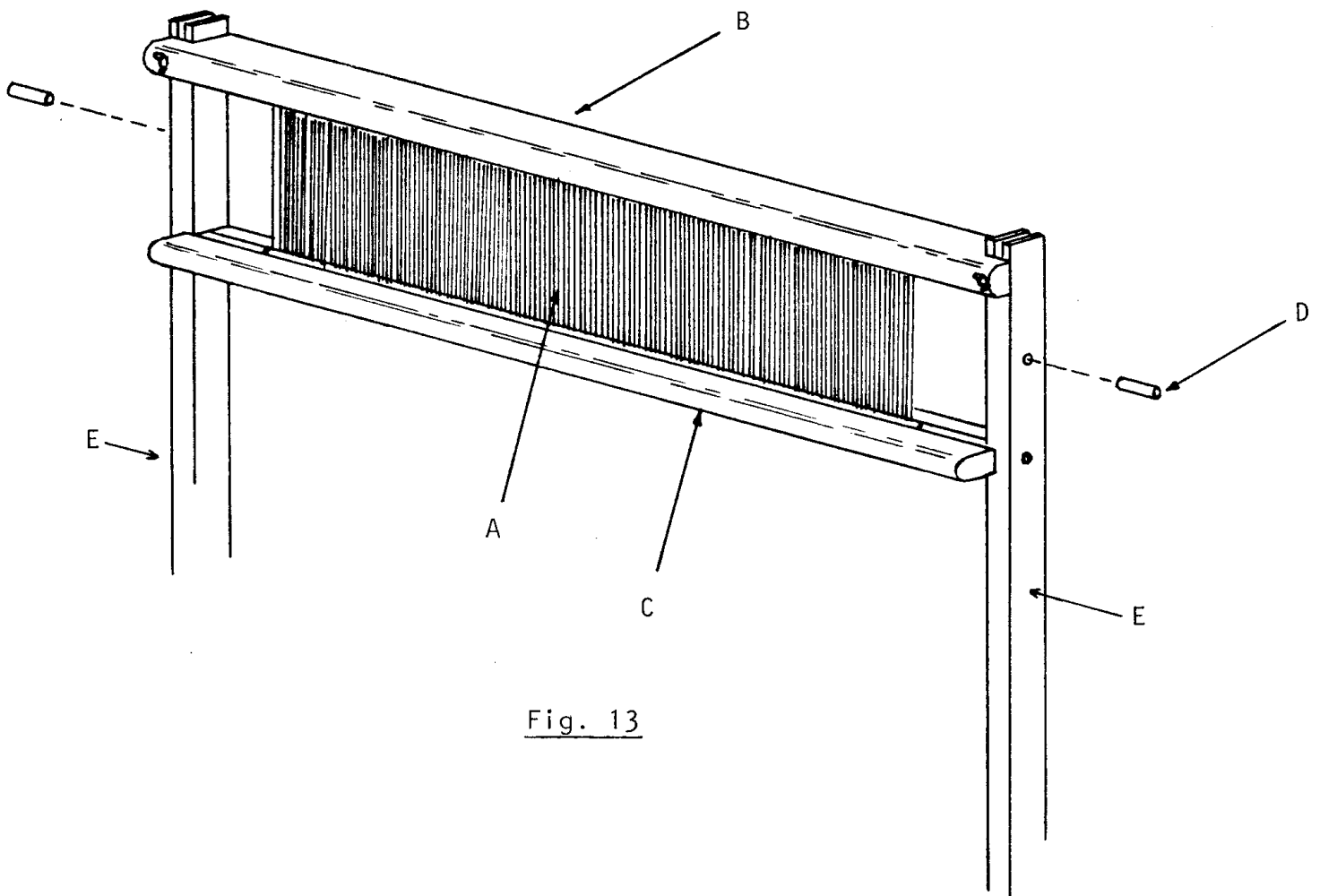

Fig. 13



Install the breast beam A with two round-headed screws 1½" (40mm) No. 14.

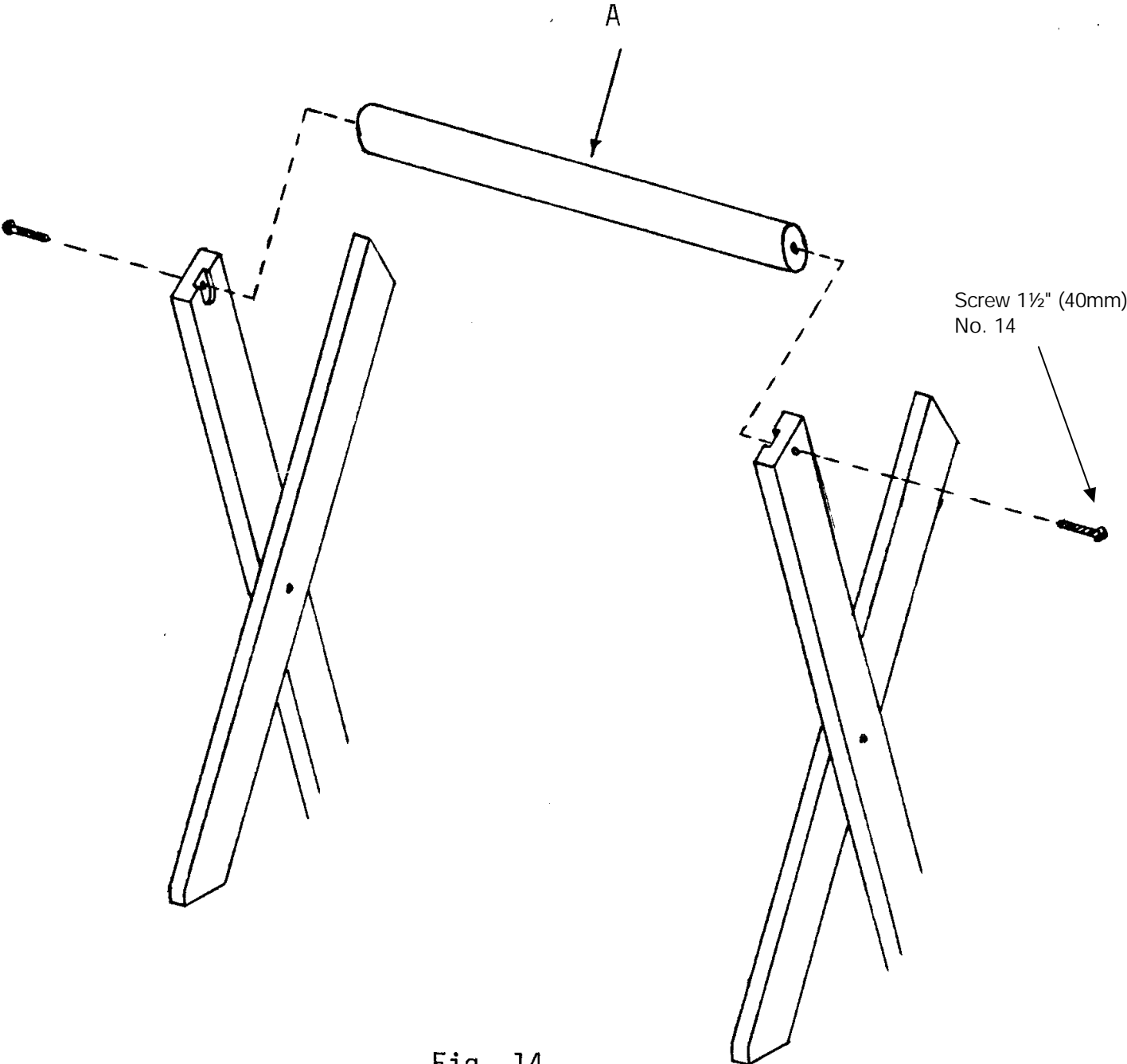
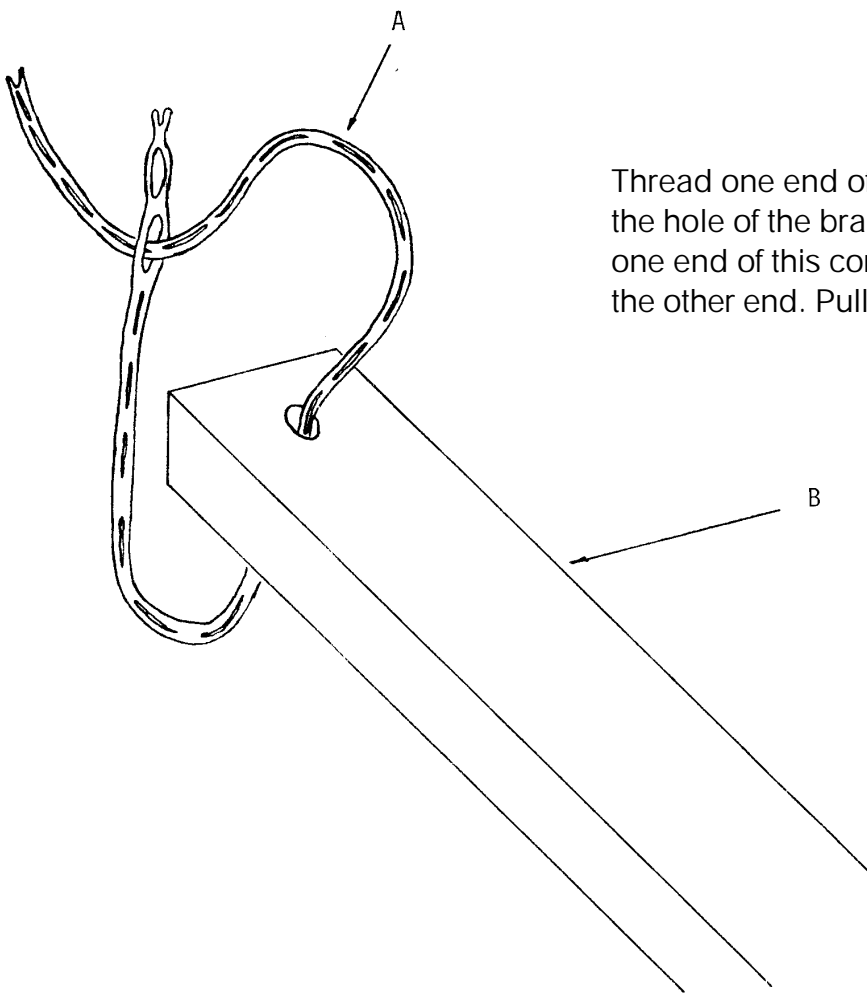

Fig. 14



Thread one end of the loop brake cord A into the hole of the brake treadle B, then thread one end of this cord into the second loop of the other end. Pull so that it makes a knot.

Fig. 15

Join the end A of the brake circle to the hook B of the brake lever.

Fix the cord C to the hook D by inserting it into the second last loop of the cord.

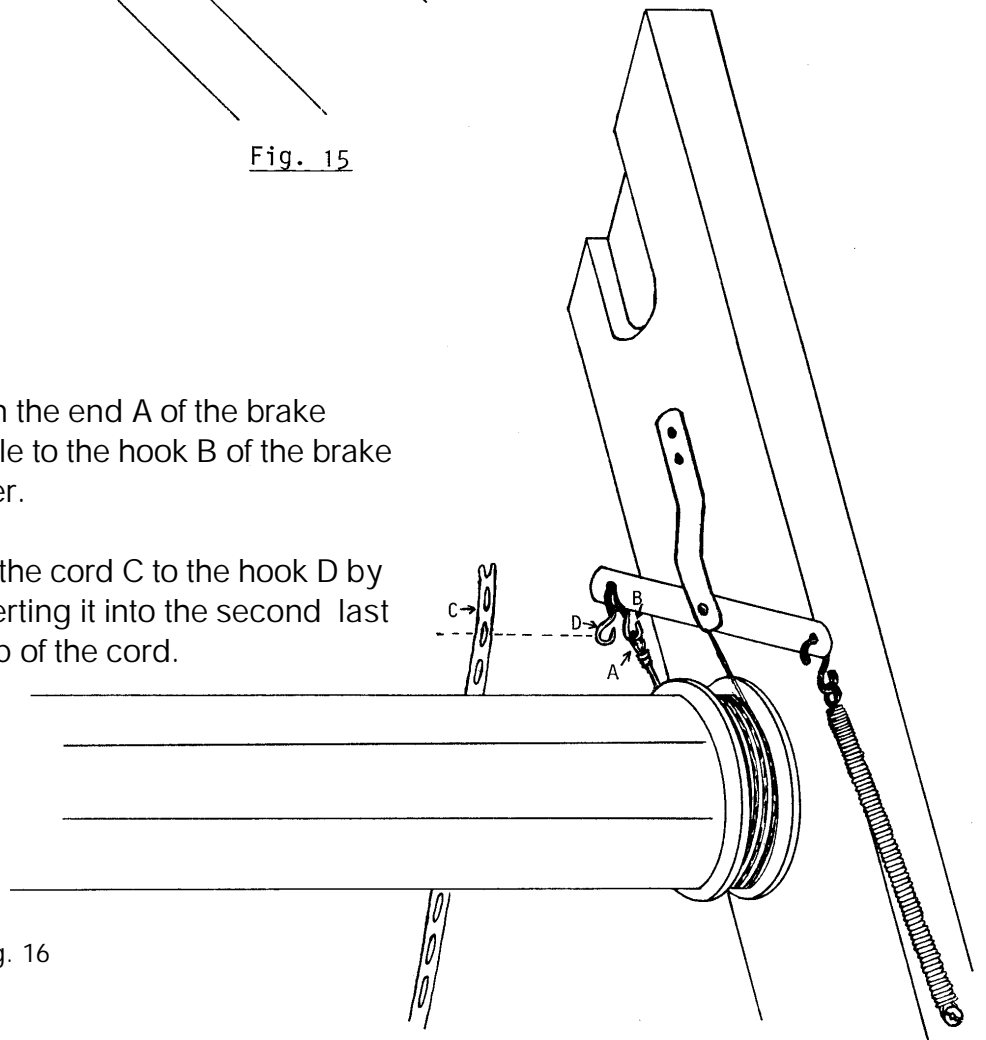

Fig. 16

Install treadle cords as shown here

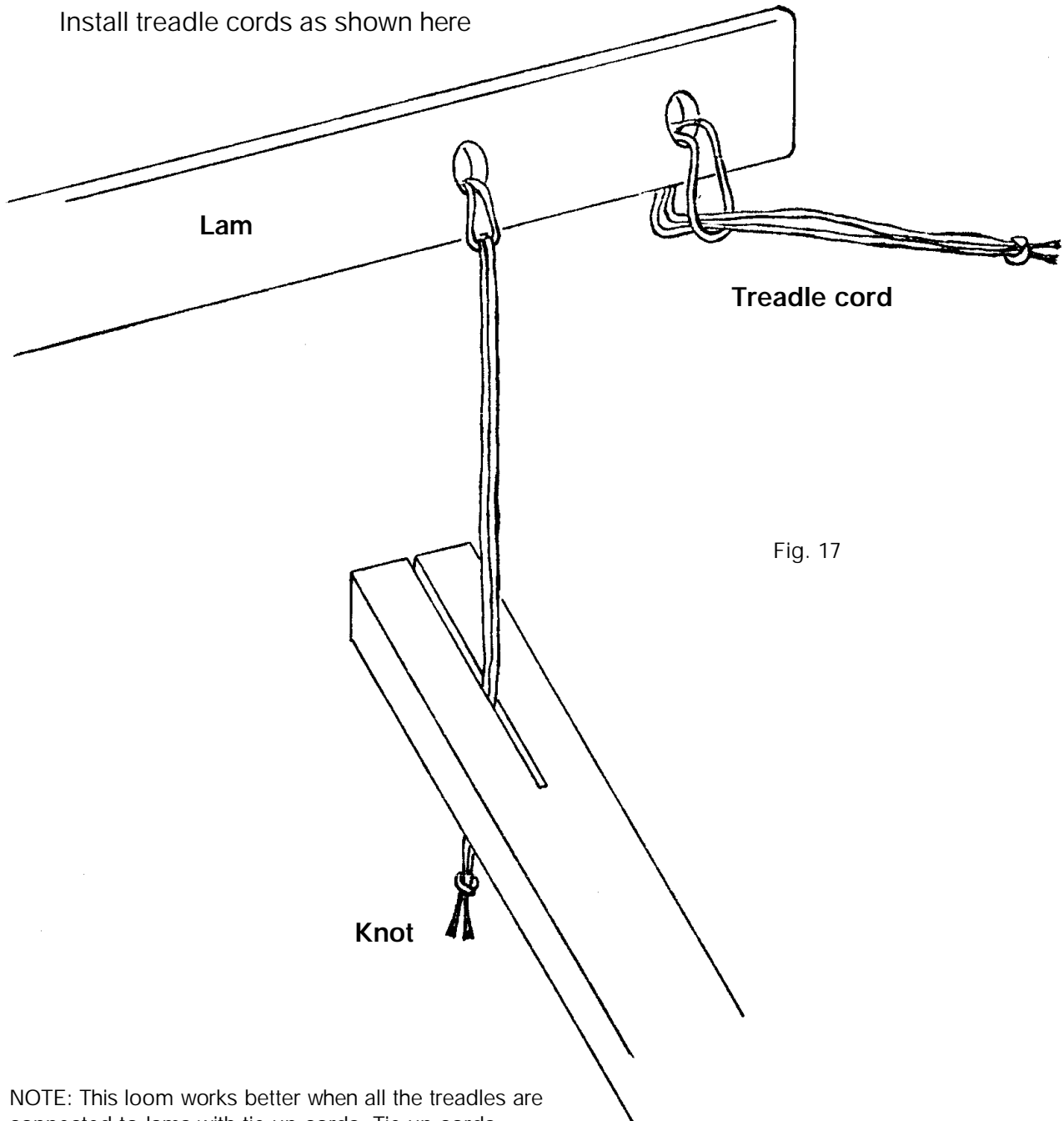

Fig. 17

NOTE: This loom works better when all the treadles are connected to lams with tie-up cords. Tie-up cords prevent the lams from jamming as the shafts go down.

# BEAMING

On this loom, beam sticks and cords have to be installed in place of the usual apron. Thread a 10 yard (9.2m) nylon cord through the middle holes of the warp beam. Then thread the two cord ends (equal in length) through the middle holes of the beam stick

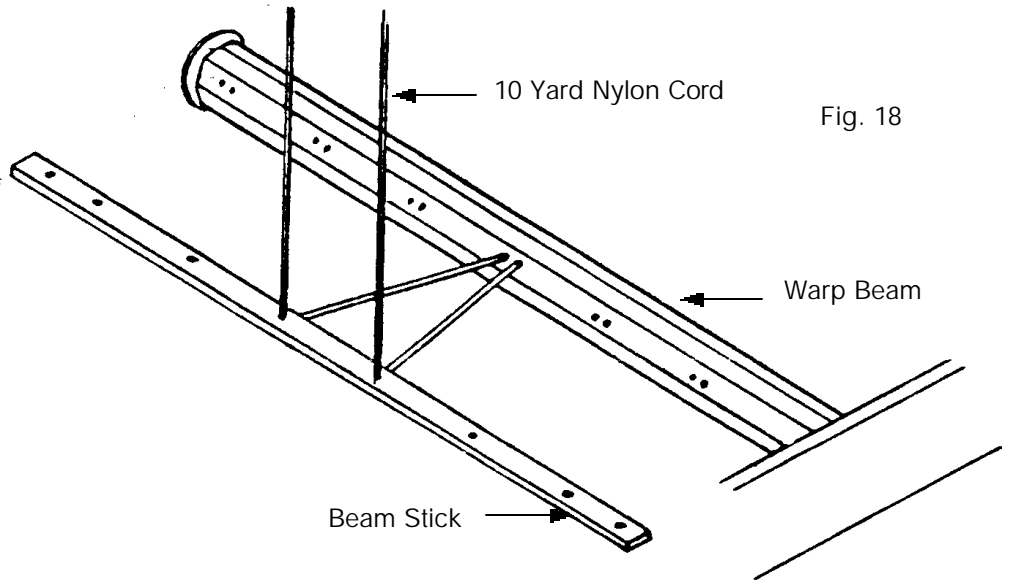

Fig. 18

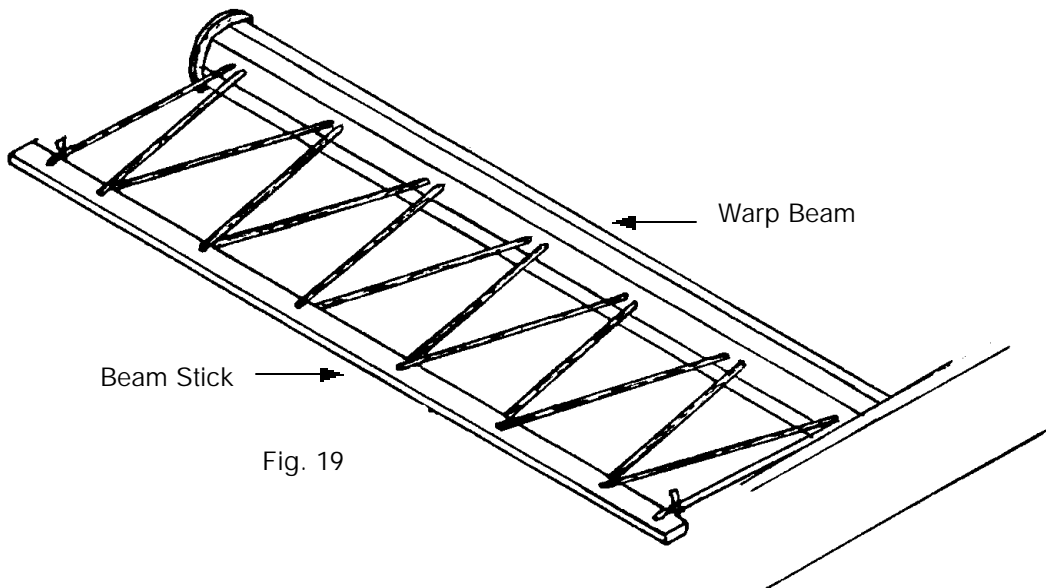

Fig. 19

Continue threading the cord through the warp beam and the beam stick. Knot the cord at each end of the beam stick. Adjust the cord so that the tension and the length are the same for the whole width of the loom.

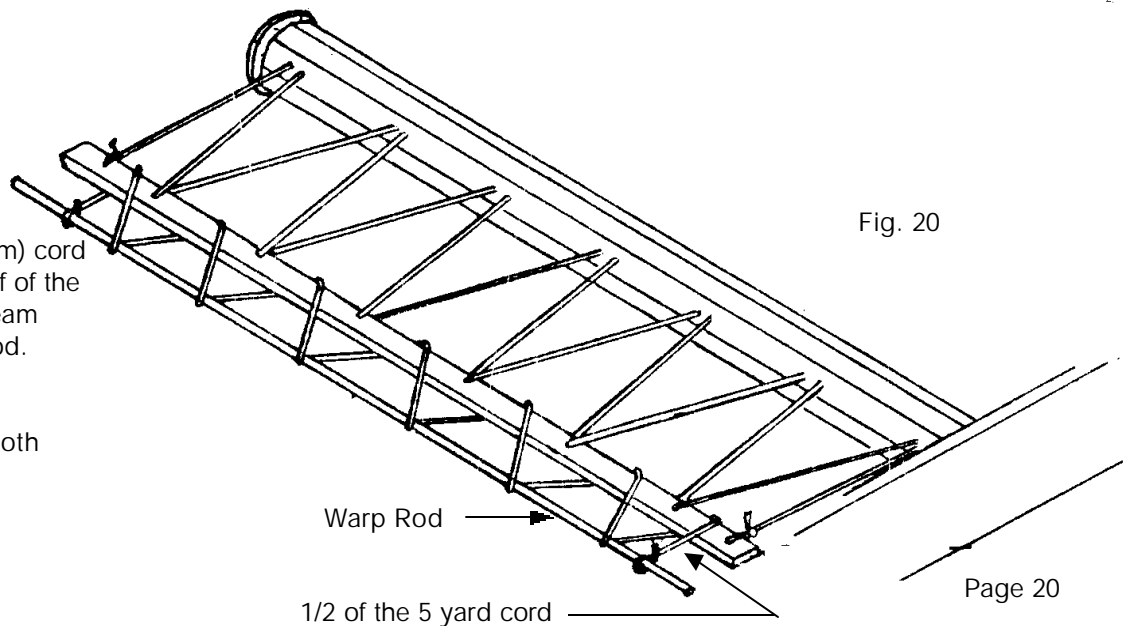

Fig. 20

Cut the 5 yard (4.5m) cord in half. Use one half of the cord to lace the beam stick to the warp rod.

Repeat the same operation for the cloth beam.

To install the heddles you can just bend the heddles supports .  
To remove the shaft frames you first have to unscrew the nut of the jack pin.  
Then pull up the shaft frame from the castle.  
We strongly recommend that you have those nuts installed at all times.

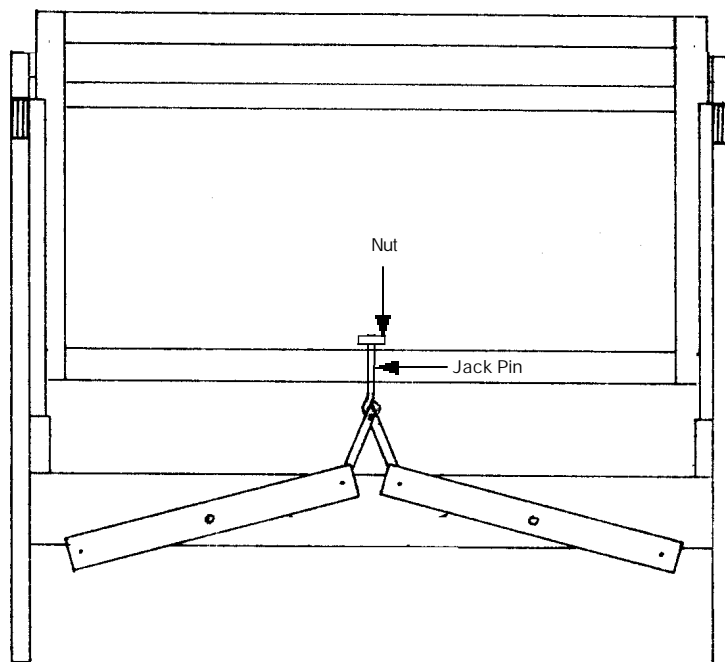

Fig. 21

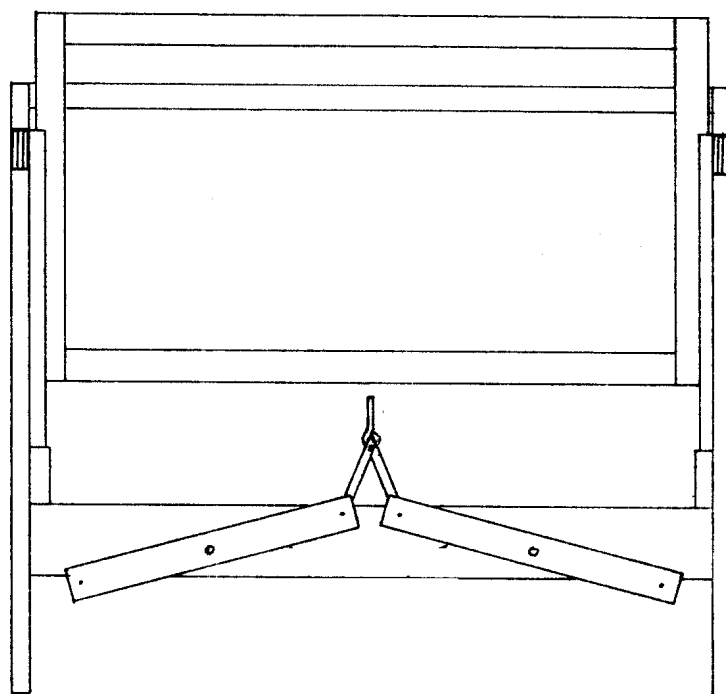

Fig. 22

**TO INSTALL HEDDLES:**

Disconnect the center of both heddle supports of a shaft frame and take it out of the end frame by bending it.

For more information, see the book supplied with the loom "Warp & Weave".

To fold the loom, release the tension by pressing the brake treadle, then loosen the plastic handles on each side of the loom and pull these upward. Tighten the handles. The loom can fold even with fabric on it.

**MAINTENANCE:**

In order to get the maximum efficiency from your loom, we recommend you periodically spray a lubricant (silicone) on the plastic slides on each side of the loom.

We at Leclerc encourage Weaver feedback on this and all our products. Please send your comments to Leclerc Loom Co.

**HAPPY WEAVING**