

## FRICITION BRAKE ON A LECLERC LOOM

The friction brake permits a fine adjustment on the warp tension. It is particularly appreciated on a fine material and on fibers without elasticity such as linen and cotton.

It has a flat wire band, called a wire brake circle, wound 3 times around a metal drum which is attached to the end of the warp beam.

One end (the one close to the frame) is attached directly to the loom. The other end is attached to a coil spring which pulls it straight down. The greater the pulling power applied to the wire brake circle the stronger the brake action.

### IMPORTANT:

When putting the brake circle on the drum, do not attempt to uncoil it or disturb its coil in any way. If uncoiled or bent, the brake will not operate properly.

To install or remove the warp beam from the loom, insert or extract the brake drum from the wire circle.

It is also important to check the wire brake circle to insure that none of the coils overlap each other and that they are all in their proper place on the brake drum. These items are critical to the proper operation of the brake.

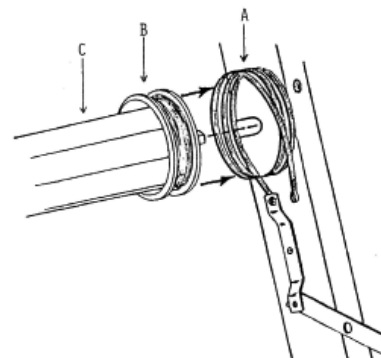

When you stand near the brake (right side of the loom), the beam must turn clock-wise but **lock completely counter-clock-wise.**

On older looms or on those which have had excessive use, you may find that the brake does not hold properly. This is usually caused by dirt, lint or grease on the wire circle and brake drum. The metal parts should be cleaned with a cleaning solvent. **NEVER PUT GREASE**, oil or any type of lubricant on the brake system, as it will cause it to slip.

If the brake still does not hold properly, check if the brake drum is too smooth. If so, use a small flat file to score or roughen the surface of the brake drum to allow the wire circle to grip.

### THE BRAKE CAN SLIP IF:

- 1) the installation is wrong.
- 2) the brake drum is too smooth.
- 3) the wire circle is in bad condition (coils have to go around side by side).
- 4) the spring coil is too old and has lost power.

In order to help you install it correctly, enclosed is a drawing of most Friction Brake Systems used by Leclerc over the years. If you have another set up or have more questions, do not hesitate to contact me:

Francois Brassard

Leclerc looms

info@leclerclooms.com

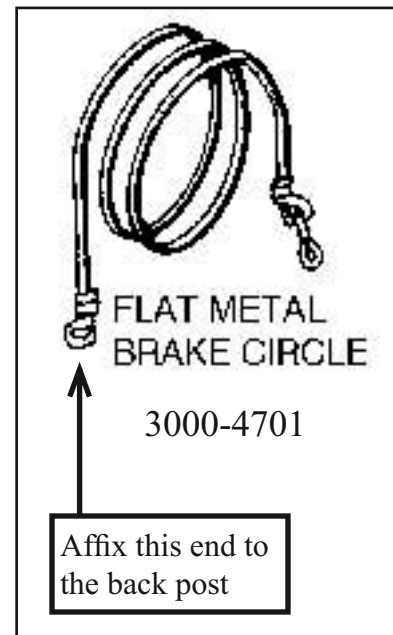
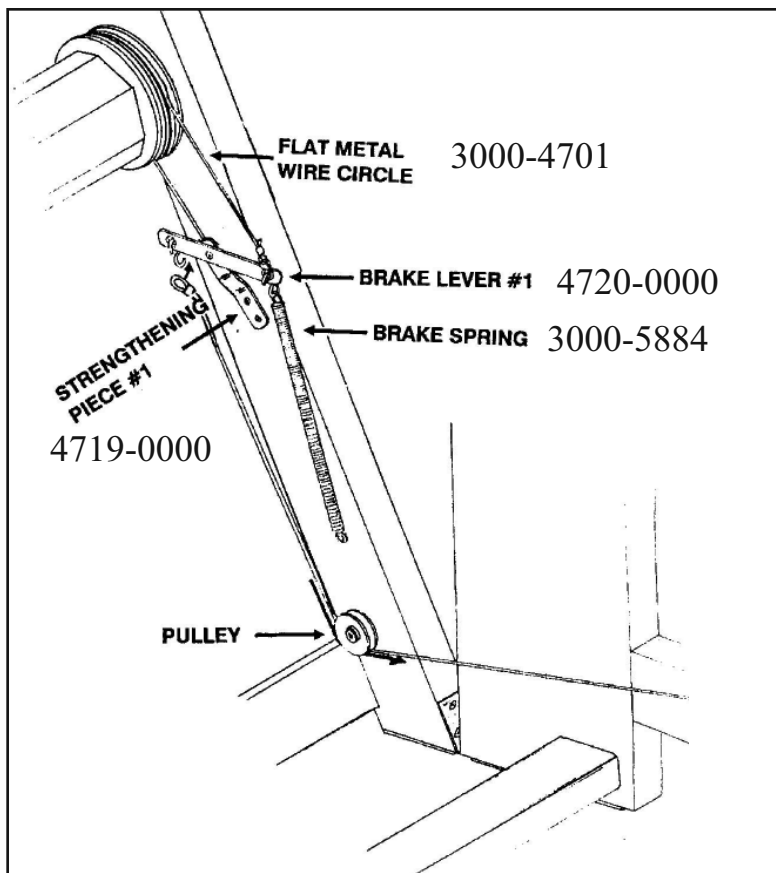
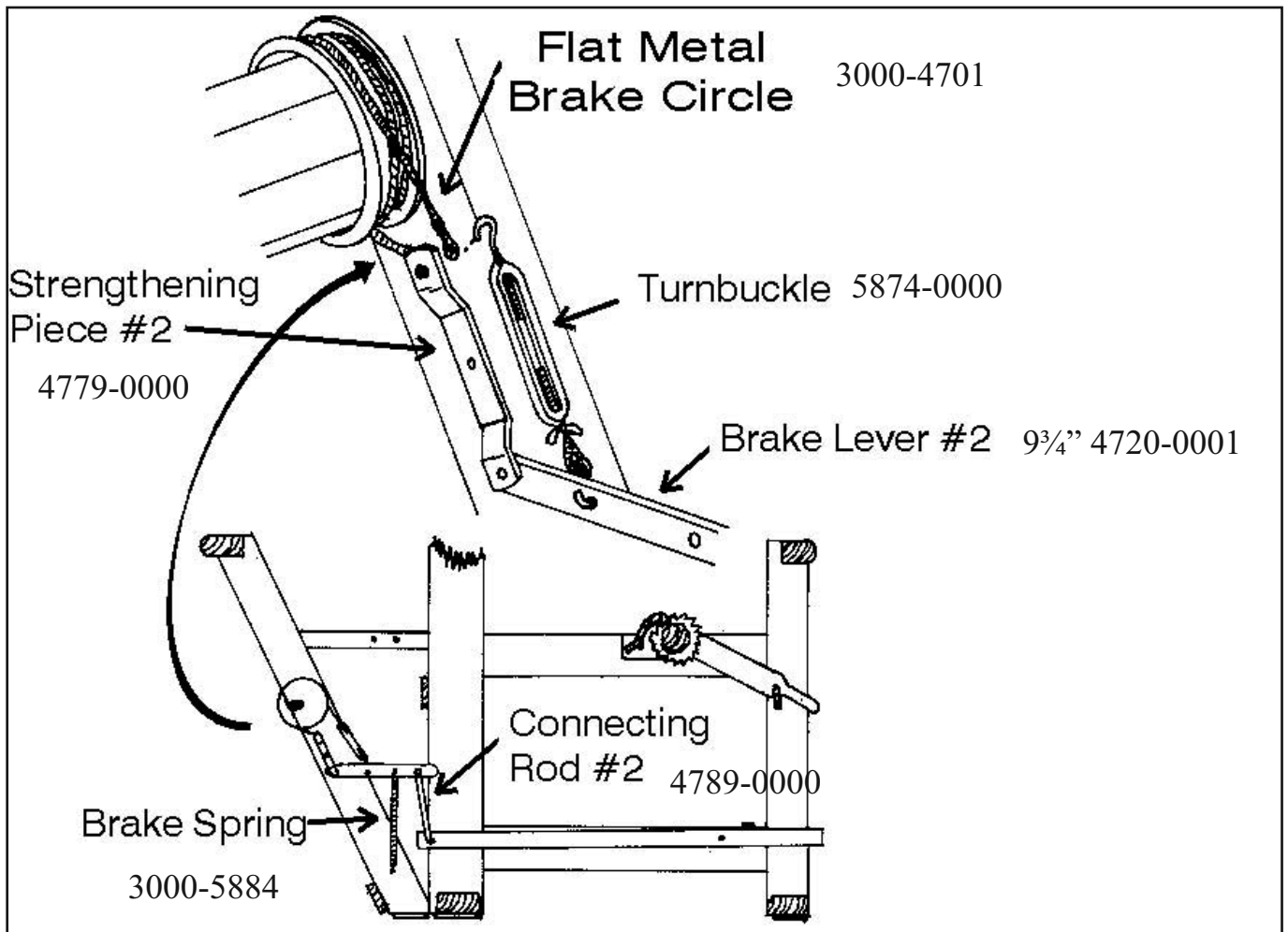

Attach the end of circular brake shoe D (brake circle)  
to the hook of spring F

Then attach cord C to the hook of brake treadle G

See "Warp and Weave" book (friction brake section  
page 87)

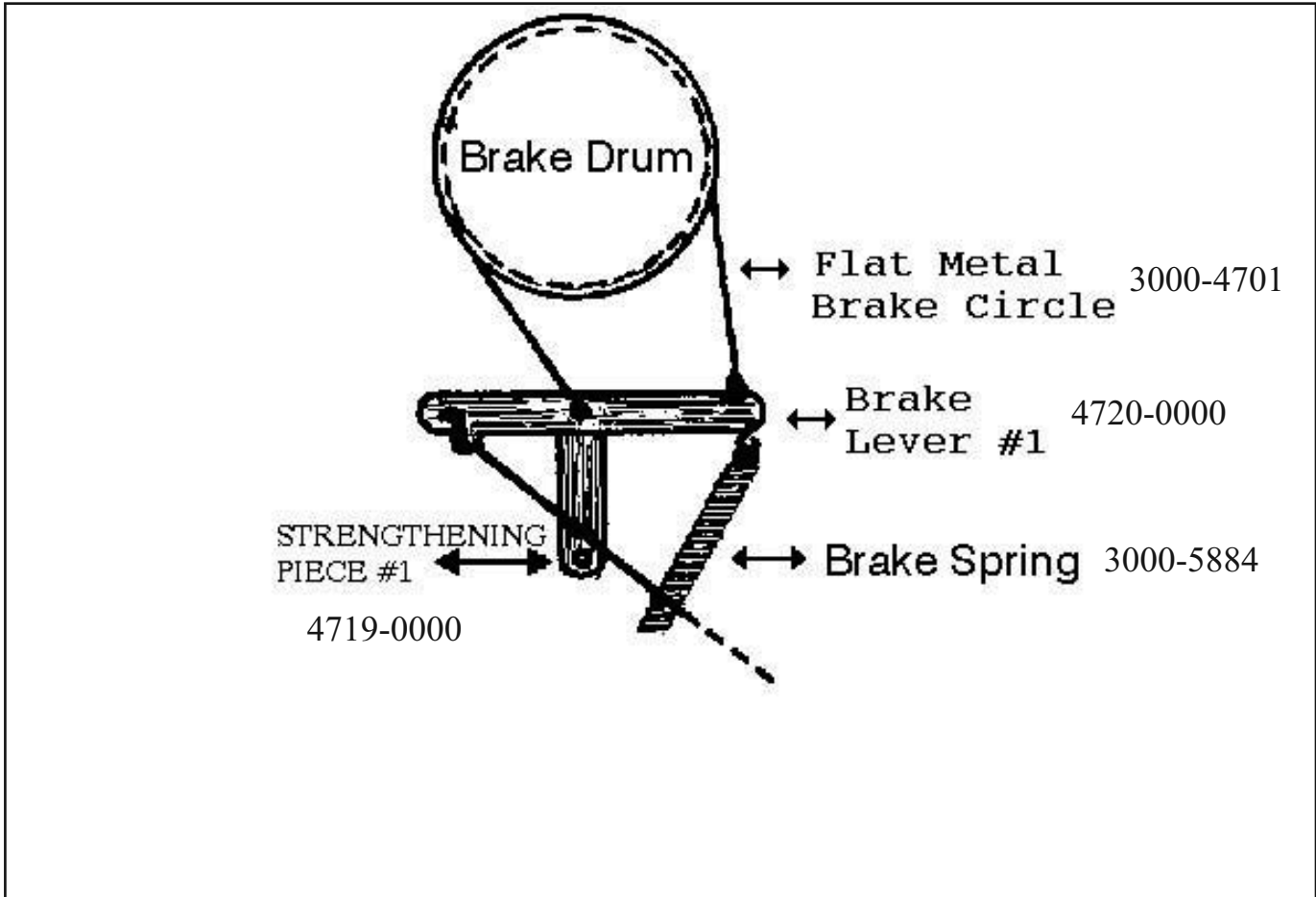
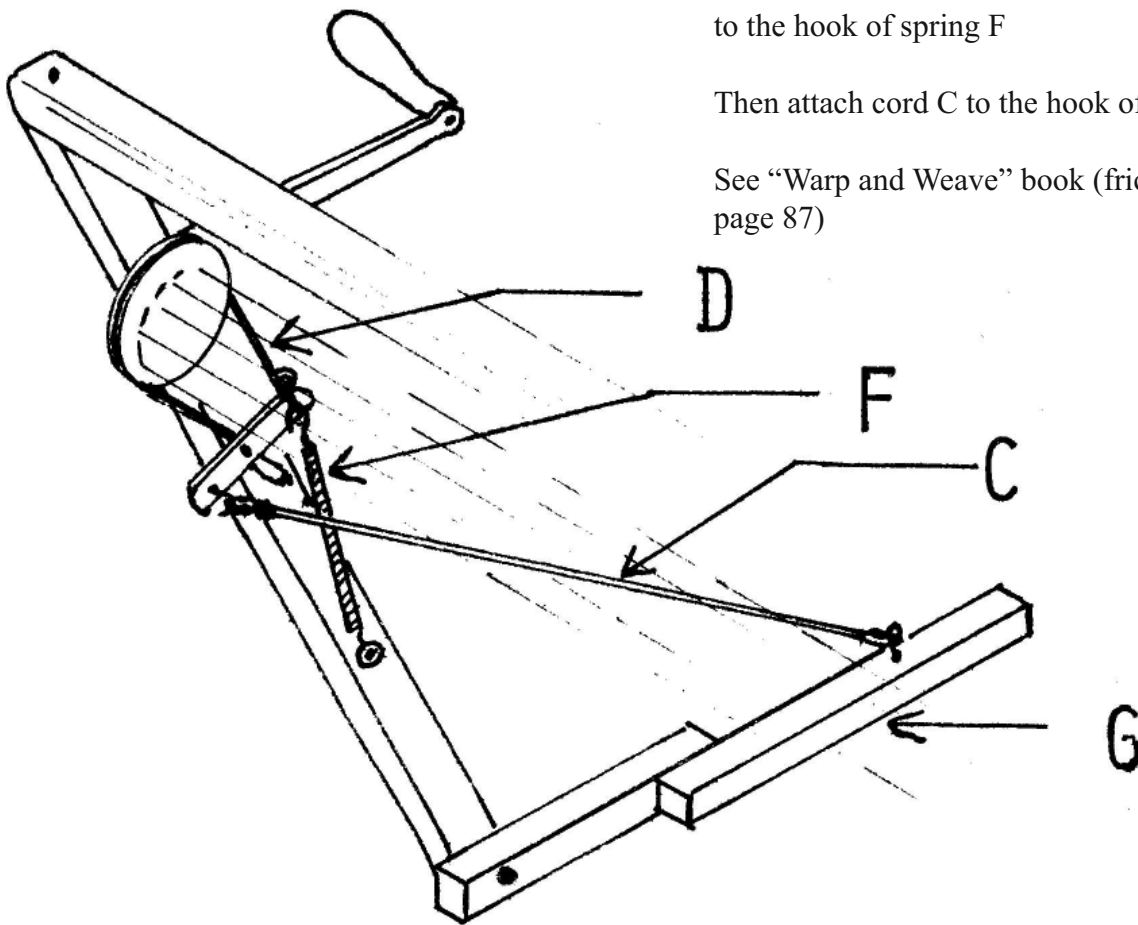

# VERY OLD MIRA SYSTEM

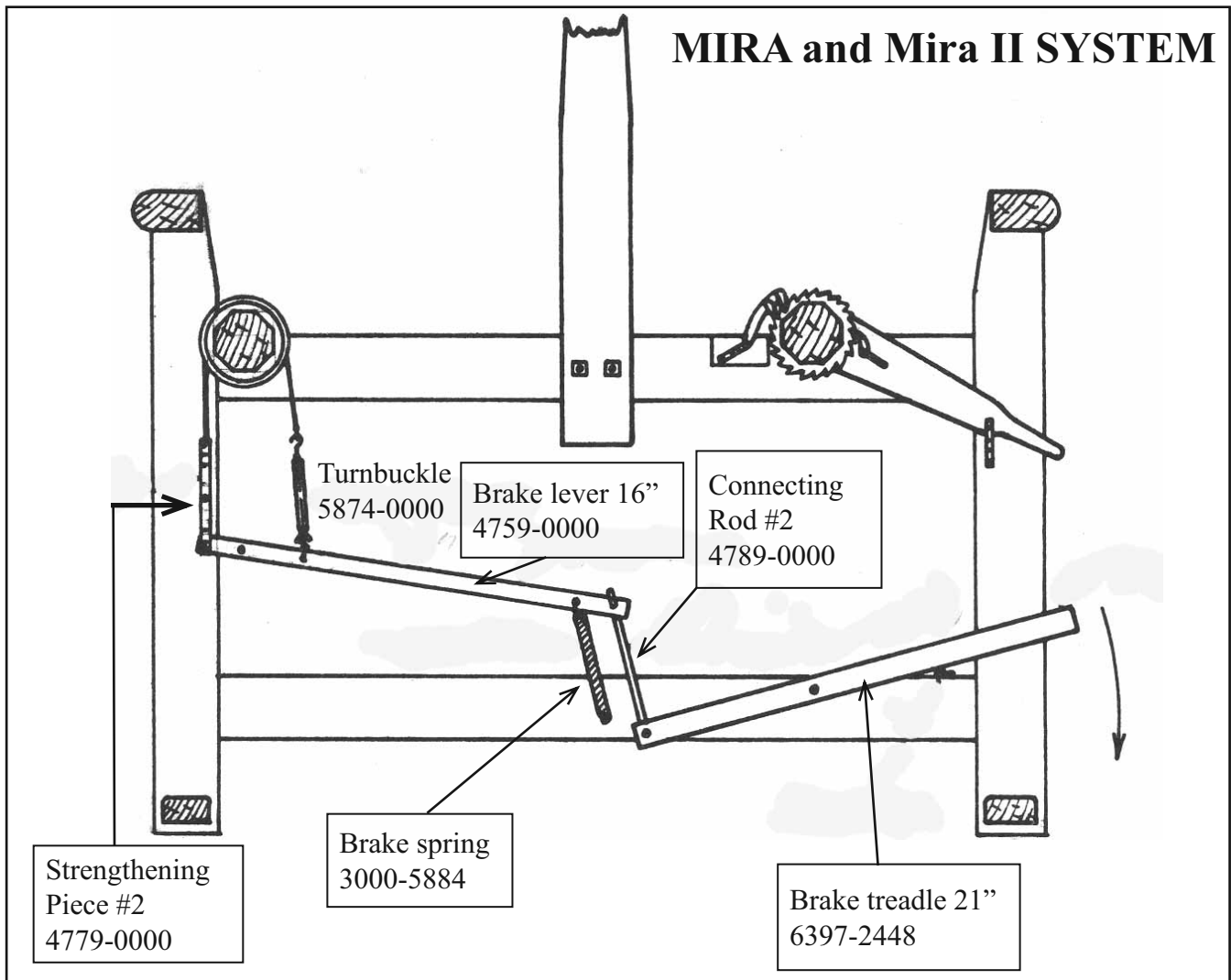
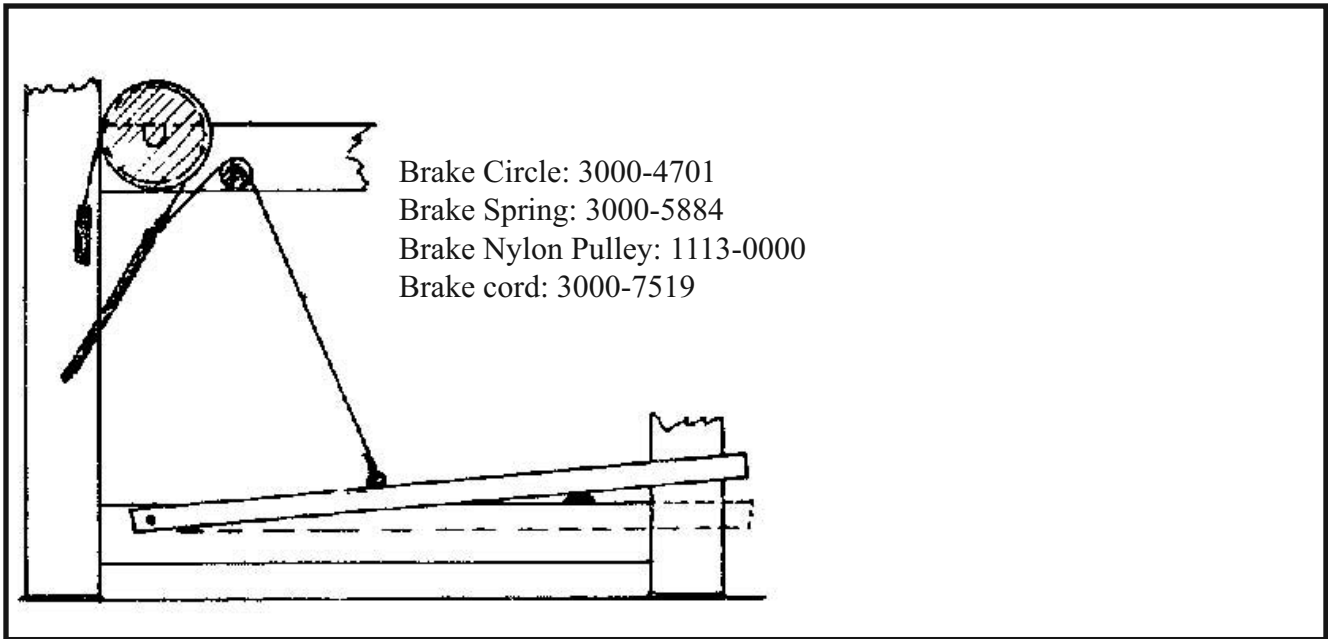

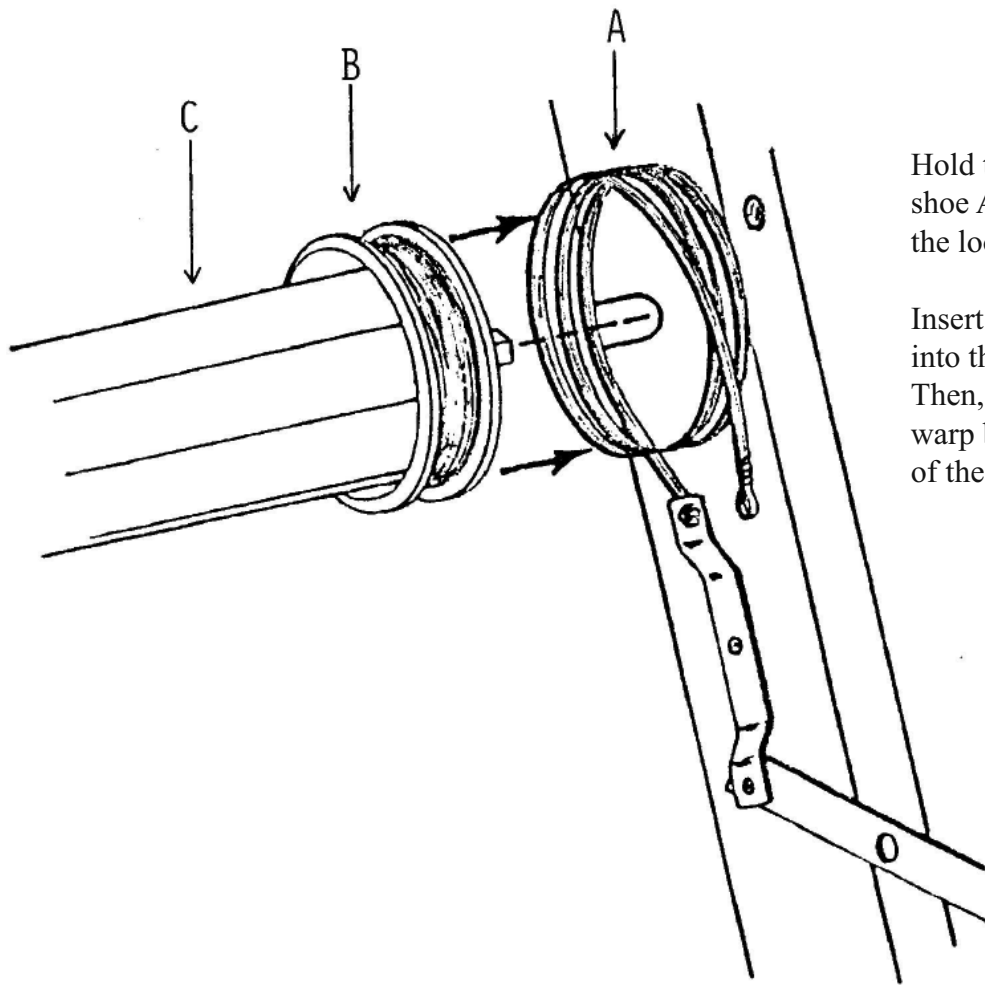

Hold the circular wire brake shoe A slightly to the rear of the loom, but do not unroll it.

Insert the brake drum B into the wire brake shoe A. Then, install the ends of the warp beam C into the grooves of the back posts.

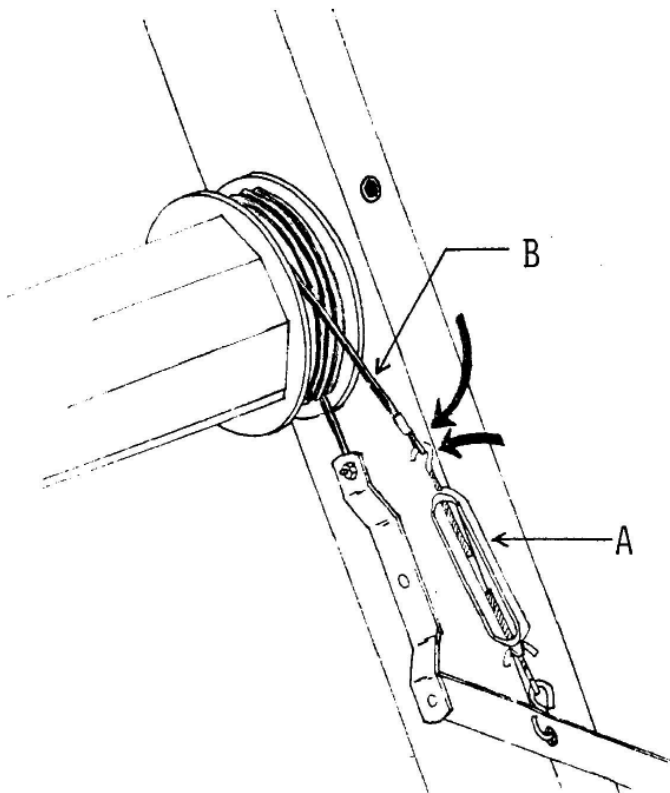

Hook turnbuckle A to flat wire circle B.

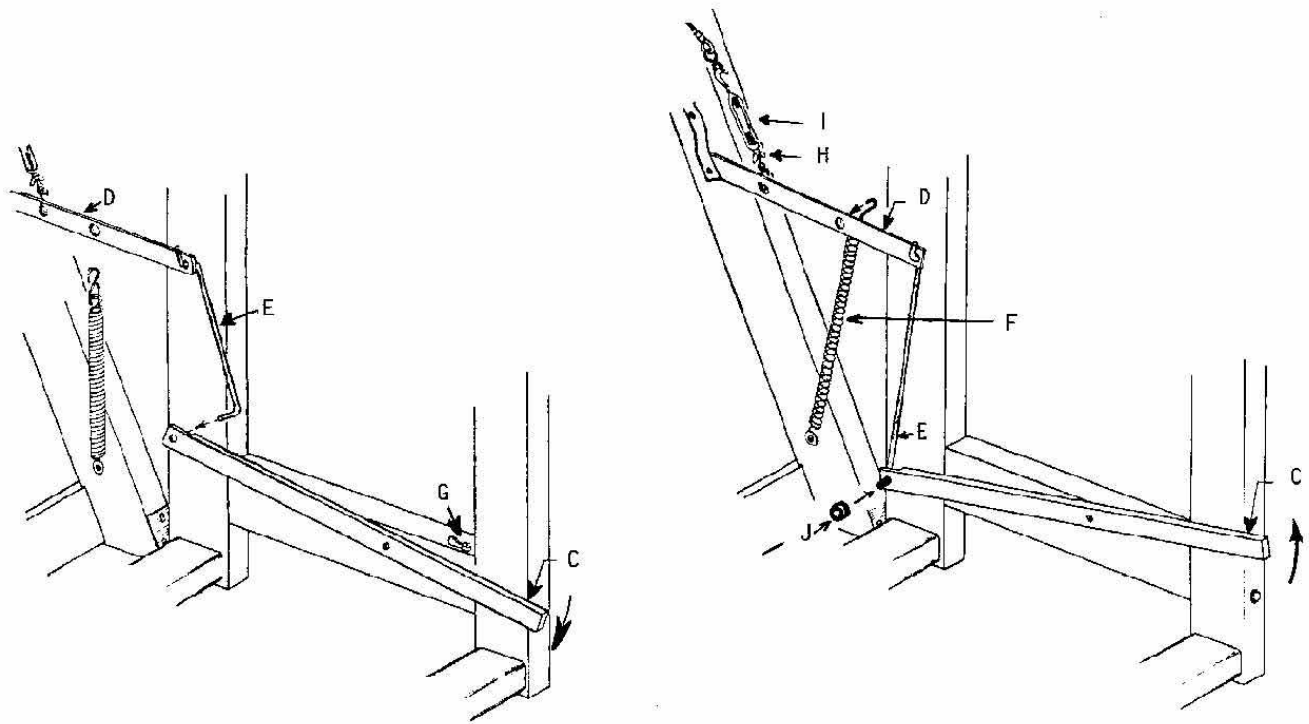

Using metal rod E, join treadle C to lever D. First insert the double-cornered end of the metal rod into lever D; then insert the other end of the metal rod into treadle C while the treadle is depressed.

Raise treadle C as high as possible then hook spring F to lever D.

#### BRAKE ADJUSTMENT:

Release the brake by depressing treadle C and locking it down with the catch G. The warp beam should turn freely but the circular brake wire should not be too slack. If the tension is too great, unscrew the wing nut H slightly and then loosen the turnbuckle I. If the tension is too slack, tighten the turnbuckle I slightly and then the wing nut H.

Add a black rubber ring J to the lower end of the rod E, to prevent the rod from slipping out.

**If the brake spring is too weak (turnbuckle completely closed) you can lower the bottom part or install a new one.**

## FOLDING LOOM AND BEAMING:

Release the brake by depressing treadle C and by locking it down with catch G. Release the 4 metal hooks and fold the back of the loom.

## WEAVING:

To advance the warp, depress brake treadle C and turn cloth beam H at the same time. Then release brake treadle C and advance the cloth beam until the next notch in the ratchet gear is reached. If this is too much tension, gently depress the brake treadle until the desired tension is obtained.

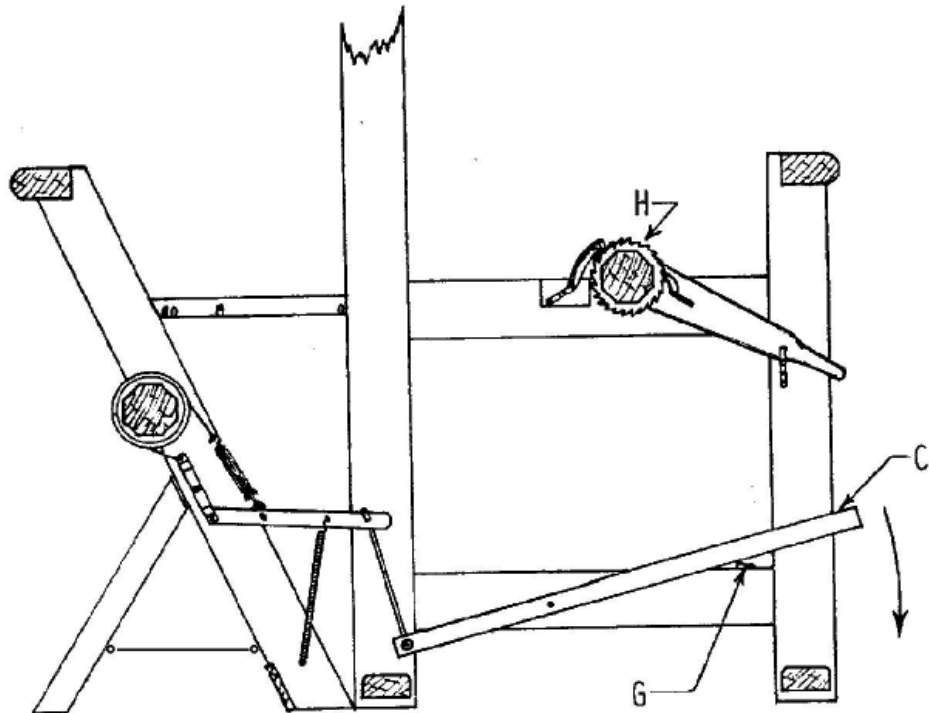

### Note while winding a warp with a Leclerc Friction Brake

To maintain proper adjustment and operation of your Friction Brake, it is recommended that the Brake be disengaged while winding the Warp.

On those looms designed with a Treadle or Lever Lock, the Brake should be locked open when winding.

### MORE INFORMATION:

See "WARP AND WEAVE"

### Warp beam advance control system (new feature 2006)

This system will eliminate excessive warp yarn advance when releasing the brake system at cloth take-up.

This friction system is adjustable and **have to be released when winding the warp on.**

Just screw the handle in to increase the friction or unscrew it to release.

Affix it to the back left side of the loom using 2 round head screws no 12 - 1" to the pre-drill holes.

