

The Leclerc Weaving Looms, a tool adapted to your needs



Voyageur Looms



End-Feed Shuttles



Coloured Shuttles

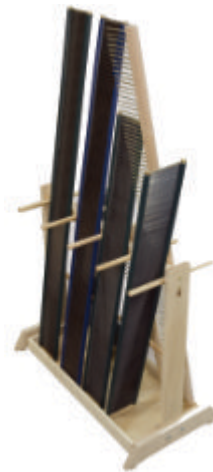

Reeds Stand



Hold-All

Back Hinge Treadles Looms



Weavebird Looms 16, 24 & 32s



Apron.....	58	Mira Looms.....	18
Artisat Loom.....	15	Netting Needles.....	46
Beam Sticks.....	58	Nilus II Looms.....	23
Benches.....	37	Nilus Looms.....	21
Bergere Loom.....	33	Penelope Loom.....	34
Bobbin Racks.....	42	Pick-Up Sticks.....	56
Bobbins.....	46	Raddles, Paddle.....	51
Carders.....	58	Reeds.....	36
Cendrel Inkle Loom.....	32	Reeds for tension Box.....	41
Clerco.....	58	Reed Stand.....	43
Colonial Loom.....	27	Repair Parts.....	62
Colored Shuttles.....	49	Rigid Heddles.....	33
Comb, Light & Heavy.....	56	Rods (steel rods).....	58
Compact Loom.....	14	Sectional Warp Beam.....	39
Cords & Treadle Cords.....	57	Shaft Frames.....	54
Counter.....	40	Shed Regulator.....	60
Cranks.....	57	Shuttles (boat).....	47
Diana 24" 16s Dobby.....	13	Shuttles (rag and ski).....	49
Dividers.....	41	Tapestry Bobbins.....	56
Dorothy 15 ³ / ₄ " Loom.....	11	Temples.....	55
Dorothy V2 24" Loom.....	12	Tension Box.....	40
Double Warp Beam.....	60	Tension Box Extension.....	40
Drop Spindle.....	51	Tension Box Reeds.....	41
End-Feed Shuttles.....	48	Threading Helper.....	52
Fanny II Loom.....	19	Theadle Hooks and Cords.....	57
Flat Shuttles.....	46	Voyageur 15 ³ / ₄ " 4s, 8s or 12s....	7
Flying Shuttle Beater.....	59	Voyageur 24" 4s, 8s, 12s or 16s	10
Fringe Twister.....	45	Warp Sticks.....	57
Gobelin Loom.....	35	Warping Mill (Warping Boards)	50
Guide for Sect. Warp.....	41	Weavebird Looms.....	29
Hold-all.....	42	Weaving Books.....	63
Heavy Comb.....	56	Weighted Beater.....	61
Heddles.....	53	Winders.....	44
Hooks.....	55	Wool Carders.....	58
Kebec II Looms.....	31		
Lease Sticks.....	58		
Light Comb.....	56		



GENERAL INFORMATION RELATING TO ALL LECLERC LOOMS

All Leclerc looms and accessories are guaranteed for one year, covering materials and workmanship. Parts are replaced free of charge upon proof of defect.

All Leclerc looms are made of selected, well-seasoned, kiln dried Canadian maple except for the harness frames and a few parts that require a lighter wood.

The metal pieces are of aluminum dye cast, cast iron or steel protected by metal zinc plating. Heddle support bars are now stainless steel.

Looms are pre-packed with their assembly equipment.

All looms are shipped partially knocked down for easier handling. Assembly is simple and instructions are included.

On all Leclerc looms, the tie-up system is very simple. Nylon cords insure years of service.

All floor looms have non-sliding polyvinyl pads under the uprights.

A plain warp beam is supplied with each loom. However, a set of rake-like pieces can be added to the pre-drilled warp beam to convert it into a sectional warp beam for direct beaming. (see sectional warp beam system)

The looms always have two treadles more than the number of harness frames.

A weaving book, giving basic techniques and important information is supplied with each loom.

When you choose a Leclerc loom, you buy from a company that:

- » guarantees its products
- » gives prompt delivery
- » offers replacement parts
- » sells you a loom that has excellent resale value.

Your Leclerc dealer can help you in choosing your equipment and will insure you receive after sales service.

TECHNICAL INFORMATION

Counterbalance Loom, Jack-Type loom, Countermarche loom or Jack-Type with back hinge treadles

1) COUNTERBALANCE SYSTEM

The threads (in normal position) from the front breast beam to the back thread beam are in the center of the heddle eye and reed.

When shafts one and four are pulled down by the action of one or two lams and treadles, shafts two and three automatically move up, from the action of the lower rollers, giving a large, clean shed.

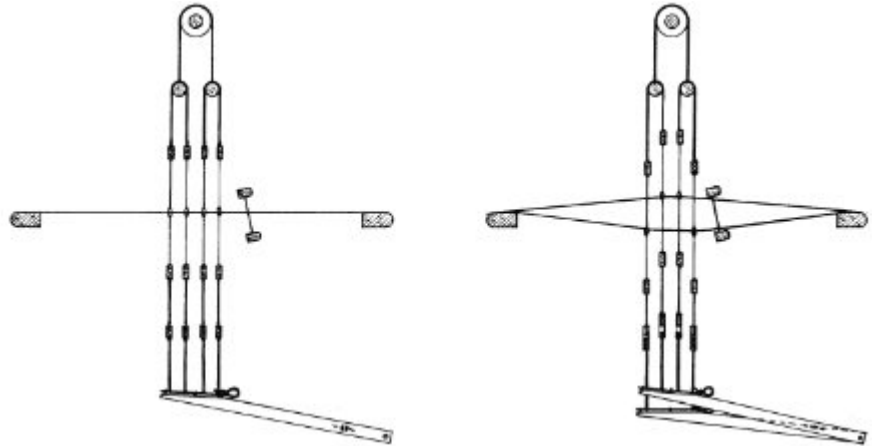

ADVANTAGES:

- Large, clean shed
- Effortless treadling
- Good system for rug making when high pressure is needed on the warp
- Easy threading because you have to attach only the shaft you want to lower.
- You always have the same tension on the upper and lower warp threads
- Less expensive than other systems.

DISADVANTAGES:

- You are always limited to 4 shafts.

It is always more difficult to have a clean shed with an uneven threading like 3 shafts

2) JACK-TYPE LOOM

With this type of loom, the threads (in normal position) rest at the bottom of the reed, on the shuttle race.

If a treadle tied to shafts #2 and #3 is pushed down, the jacks will raise these shafts, while all the others remain in place.

This kind of shed can be very large or small depending on the pressure there is on the warp threads and how many threads there are. For example, it is easier to obtain a clean shed with a 36" loom that has 20 threads per inch than with a 60" loom with 40 threads per inch. The more threads and tension you have the more difficult it will be to raise the shafts.

ADVANTAGES:

- You may have more than 4 shafts (8, 12, 16)
- Threading is easy
- Loom assembly is easy
- You can change from 4 to 8 shafts at any time.

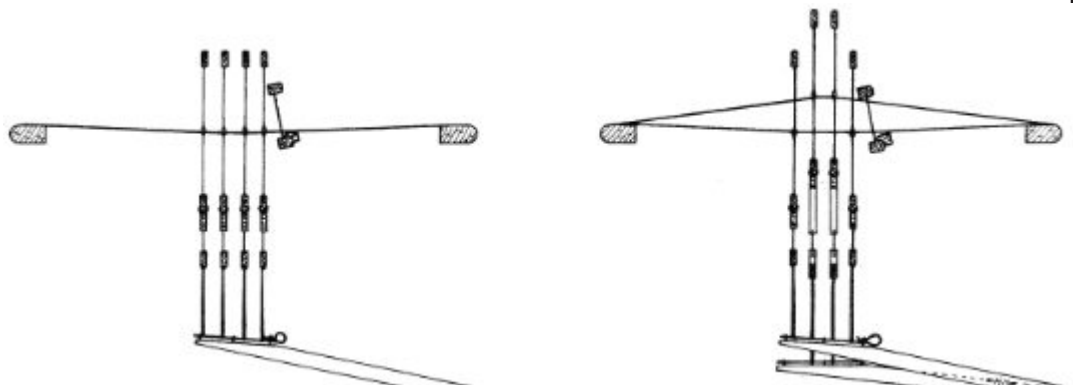

DISADVANTAGES:

- More tension to the warp requires more effort to raise the treadles; it

may reduce the size

of the shed.



3) COUNTERMARCHE SYSTEM

This system resembles the counter balance loom and has the same advantages without its disadvantages. Instead of having the rollers at the top of the harnesses, the system has one set of lams, two sets of pulleys above the shafts and one set of pulleys below.

In our diagram you can see the treadle pulling down shaft #1 while the other three are lifted by the action of the lam. When the lam moves down, the cord attached to it goes around the lower pulley, then around the upper one, lifting the shaft attached to it.

In a countermarche loom, every shaft is actively involved in each shed: each shaft is either lifted up or pulled down by each treadle. Unbalanced sheds like 3 shafts against 1 are always large and clean .

Because you actually lift or pull down every shaft, you never have any problem with one shaft lifting when it should not.

ADVANTAGES:

- Always gives a clean shed
- Effortless treadling
- Quiet
- You always have the same tension on the upper and lower warp threads

DISADVANTAGES:

- More tie-ups are needed before you begin to weave because you have to connect every shaft to the treadles you will be working with.

For a 10 treadle pattern, 80 tie-ups have to be made under the loom.

- The shaft combination is limited by the number of treadles on the loom.
- More expensive loom.

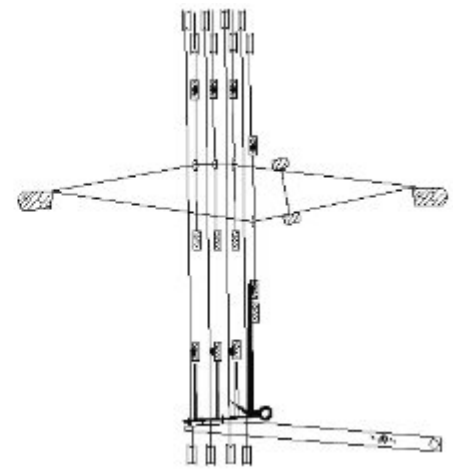
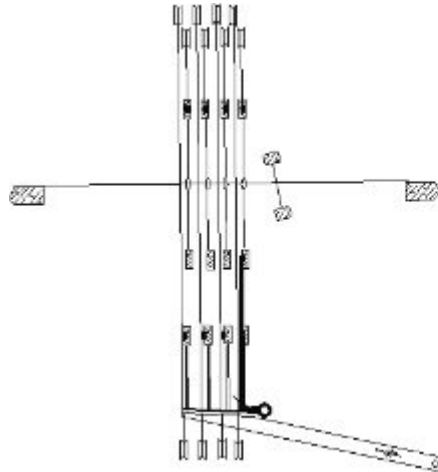

4) JACK-TYPE LOOM WITH NEW TREADLING SYSTEM

Jack looms are known for their simplicity, versatility and ease of tie-up. With proper care a Leclerc Jack Loom will provide a lifetime of weaving enjoyment.

As with all Loom designs there are some tradeoffs. With the Jack Loom the problem most often cited was the difficulty in getting a good shed with 6+ Shaft weave construction. Our new design has overcome this problem.

The new design features the Treadles anchored at the rear of the Loom, with a new unique, Rocker mechanism that insures even tension on all Treadle Cords with the Treadles in both the rest or depressed position.

This new design provides the weaver with the ease of Leg Treading multi- Shaft designs, comparable to that of a 4 shaft. In addition, a wide, clean shed was obtained on all Shafts.

We, at Leclerc, are very excited about this new Jack Loom Treading concept. In our opinion, it is the best system on the market.

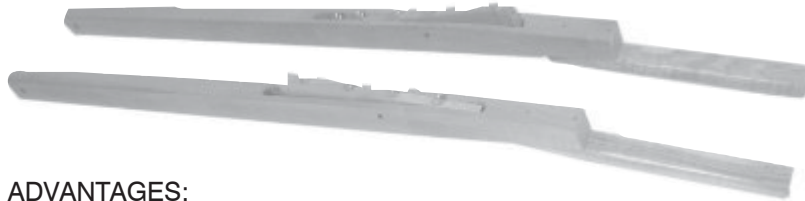

ADVANTAGES:

- Always provides a wide, clean shed even when weaving high warp tension designs such as Rugs.
- Effortless treadling.
- Threading is convenient.
- Available in 4, 8 and 12 Shaft Capacity.
- Complete instructions provide easy assembling with basic hand tools

DISADVANTAGES:

- Looms and Kits are slightly more expensive.
- The treadles must be unhooked and removed to completely fold the back of the loom.



IMPORTANT DIFFERENCES BETWEEN NILUS AND NILUS II MODEL LOOMS

Historically, the "Nilus" model loom was the first of the two models to be introduced by Leclerc. It is a 4 shaft jack type loom upgradable to 8 shafts. The "Nilus" loom is the smaller and more compact and is equipped with 10½" heddles. The "Nilus" model Loom was probably the most popular Jack Loom in the world and, along with the "Mira" and "Fanny" counterbalance models, made up the backbone of the Leclerc market line-up for most of the company's early growth years. In the 80's Nilus Leclerc Loom Co. decided to introduce a new model Jack Loom that would have the major advantage of being able to be converted from jack 4s to counterbalance 4s, and back. At that time it was decided to stop production on the Nilus. In addition to being convertible, the "Nilus II" loom utilizes 12½" heddles that offer a wider shed, and is deeper providing easier Treading on the higher tension constructions. It takes slightly more floor space than the Nilus. In 1998 after receiving many requests from customers, we reintroduced the "Nilus" model. We now offer both models in 4 and 8 shaft Jack-Type. The Nilus II is also available in 4 shaft counterbalance or 8 shaft Counterbalance. Both models are also available with "Back Hinge Treadles". The "Nilus" model loom is especially appealing to those weavers with shorter legs.

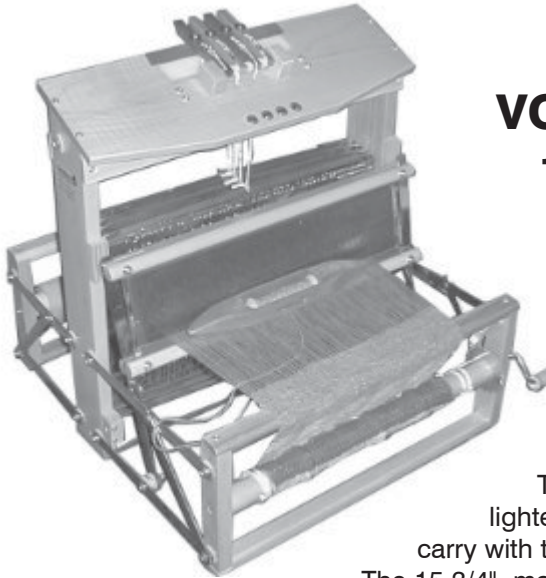

VOYAGEUR 15³/₄" 4s

STANDARD EQUIPMENT

- » Stainless Steel Reed, 12 dents/inch
- » 1 boat shuttle 6122-0000
- » 1 reed and heddle hook 6141-7000
- » 2 metal lease sticks
- » 10 loop cords for lashing
- » Transfer heddle Bars
- » Instructions
- » Book "Warp and Weave"

We at Leclerc designed the Voyageur loom following demands for an 8s loom with front levers and easy portability.

This 4s Voyageur has the advantage of being smaller and lighter. It is for the beginner or those who just want a 4s to carry with them even for a weekend.

The 15 3/4" model weighs in at 12½ lbs., comes with 400 inserted Eye Heddles, a Stainless Steel Reed and a Custom made Bag with pouch. As with the 8s loom, we supply a specially designed (1" profile) Cherry Shuttle, Reed and Heddle Hook, 2 Lease Sticks, 2 Beam Sticks, the newly designed Warp and Cloth Roll lashing system, one Multi bits Screwdriver, transfer Heddle Bars and the Book "Warp and Weave" by Robert Leclerc. Our new Voyageurs are set up with Levers starting with #1 on the right (standard). If you prefer we can set your Loom up with #1 Lever starting on the left at no extra charge. In addition for those who choose, Texsolv Heddles and the new Swinging Beater are available at no extra charge. For those who prefer even greater versatility, the Swinging Beater is also available as a Kit. The Beaters can be interchanged in a few minutes.

(2120-0916) \$163.00

SPECIFICATIONS & DIMENSIONS	
Weaving width	15 ³ / ₄ " 40 cm
Quantity of heddles	400
Loom width	19" 48 cm
Depth	19 ³ / ₄ " 50 cm
Height	20" 51 cm
Net weight	16½ lbs 7 kg.
Dimensions when folded	13" x 9" x 20"



2120-0416 15³/₄" 1113.00



Voyageur 12s 15³/₄"
on a Dorothy table
6312-2000 \$336.00.00



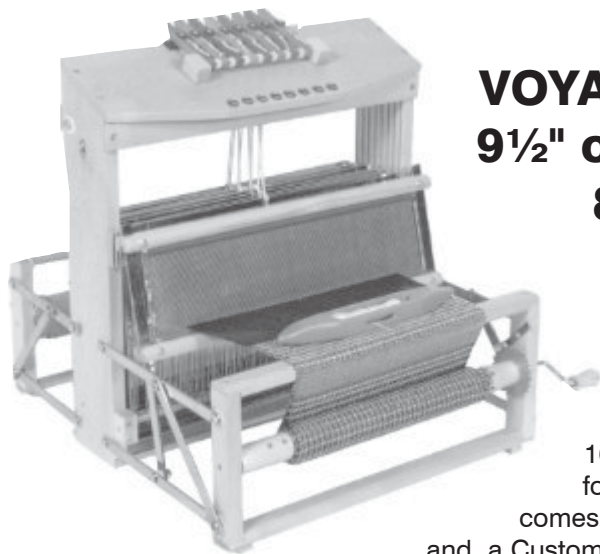

VOYAGEUR

9½" or 15¾"

8s

STANDARD EQUIPMENT

- » Stainless Steel Reed, 12 dents/inch
- » 1 boat shuttle 6122-0000
- » 1 reed and heddle hook 6141-7000
- » 2 metal lease sticks
- » 10 loop cords for lashing
- » Transfer heddle Bars
- » Instructions
- » Book "Warp and Weave"

This loom originally made for Workshop travellers ended up to be a practical loom for all weavers, beginners or more experienced ones. The 9 1/2" model weighs only 16 lbs., has 8 Shafts with front Levers, will fold to slide under an airline Seat(most larger commercial), comes with 300 Inserted Eye Heddles, a Stainless Steel Reed and a Custom made Bag with pouch for Tools and misc. items. The 15¾" model weighs in at 20½ lbs., has 8 Shafts with front Levers, will fold for checking in at the Counter(no hassle), comes with 400 inserted Eye Heddles, a Stainless Steel Reed and a Custom made Bag with pouch. Both Looms come with a specially designed (1" profile) Cherry Shuttle, Reed and Heddle Hook, 2 Lease Sticks, 2 Beam Sticks, the newly designed Warp and Cloth Roll lashing system, one Multi bits Screwdriver, transfer Heddle Bars and the Book "Warp and Weave" by Robert Leclerc. Our new Voyageurs are set up with Levers starting with #1 on the right (standard). If you prefer we can set your Loom up with #1 Lever starting on the left at no extra charge. In addition for those who choose, Texsolv Heddles and the Swinging Beater are available at no extra charge. For those who prefer even greater versatility, the Swinging Beater is also available in a Kit, it can be interchanged in a few minutes. 2120-0916 - **\$163.00**

SPECIFICATIONS & DIMENSIONS

	9½" 24 cm	15¾" 40 cm
Weaving width	9½" 24 cm	15¾" 40 cm
Quantity of heddles	4 00	400
Loom width	13" 33 cm	19" 48 cm
Depth	21" 53 cm	21" 53 cm
Height	20" 51 cm	20" 51 cm
Net weight	16 lbs 7¼ kg	20½ lbs 9.3 kg
Dimensions when folded	13" x 9" x 20"	19" x 9" x 20"



2120-0009 9½" \$1237.00
2120-0016 15¾" \$1237.00



Voyageur 15¾"
 on a Dorothy table:
 Table: 6312-2000
 \$336.00



Double Warp Beam 15¾" 6432-1001 \$475.00



VOYAGEUR 15³/₄" 12s

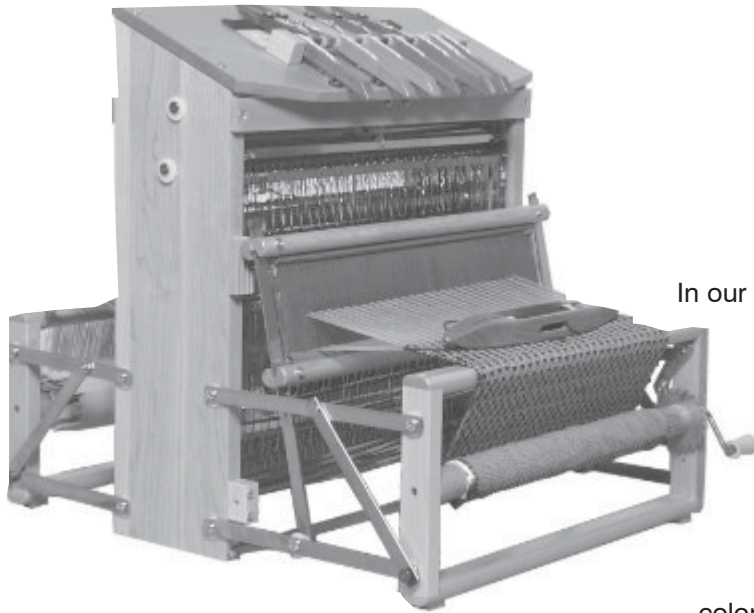

STANDARD EQUIPMENT

- » Stainless Steel Reed, 12 dents/inch
- » 1 boat shuttle 6122-0000
- » 1 reed and heddle hook 6141-7000
- » 2 metal lease sticks
- » 10 loop cords for lashing
- » Transfer heddle Bars
- » Instructions
- » Book "Warp and Weave"

In our ongoing effort to meet the workshop Weaver's needs, Leclerc has expanded its family of Voyageur Looms to include a 12 shaft, 15 3/4" model. It has all the features demanded by the weavers around the world who helped us to develop our 8 shaft Voyageur, but now has the versatility of 4 more Shafts. The standard equipment remains the same stainless steel reed, inserted eye heddles (500 for the 12 shaft), color coded levers, choice of standard or swinging beater, our designer bag for carrying, and much more. As in the original 8 shaft model, weight and ease of folding were the most important considerations. Our new 12s weighs in at 25 lbs, and will fold to an easily portable 19" x 11 3/4" (22 3/4" open) x 21". With its proven performance, we are confident that our new 12 shaft Voyageur is the best the market has to offer.

2120-1216 1579.00 \$

SPECIFICATIONS & DIMENSIONS

Weaving width	15 ³ / ₄ " 40 cm
Quantity of heddles	400
Loom width	19" 48 cm
Depth	22 ¹ / ₂ " 57 cm
Height	21" 54 cm
Net weight	26 lbs 12 kg
Dimensions when folded	19" x 11 ³ / ₄ " x 21"

Double Warp Beam 15 ³ / ₄ "	6432-1001 \$475.00
Sect Warp beam 1"	6443-1001 \$516.00

For those who prefer even greater versatility, the **Swinging Beater** is also available in a **Kit: (2120-0916) 163.00**. The Beaters can be interchanged in a few minutes.

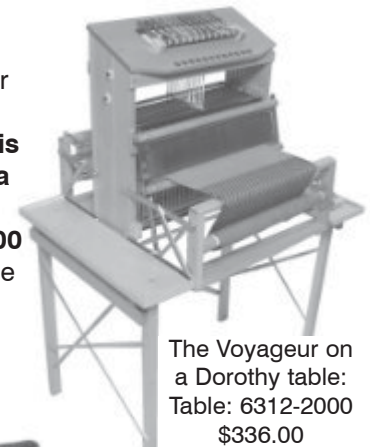

The Voyageur on a Dorothy table:
Table: 6312-2000 \$336.00

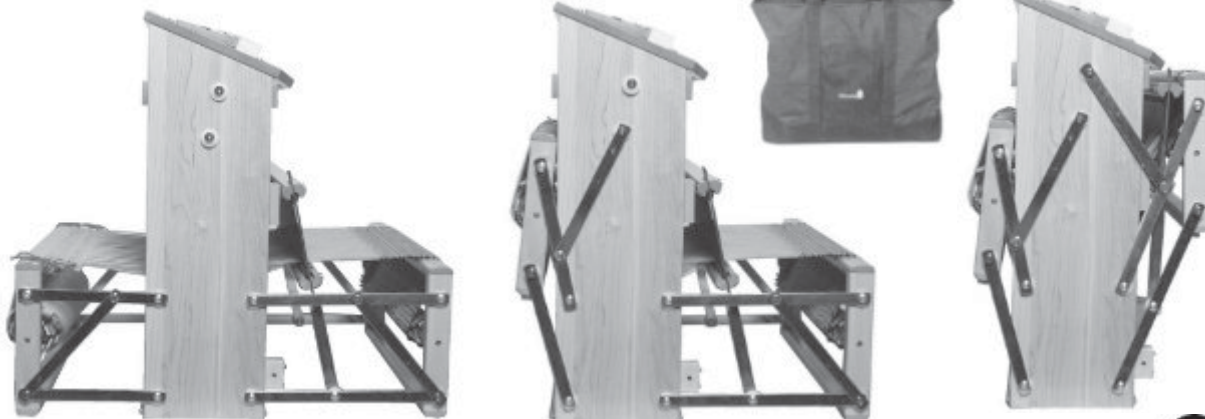

VOYAGEUR 24" - 4, 8, 12 or

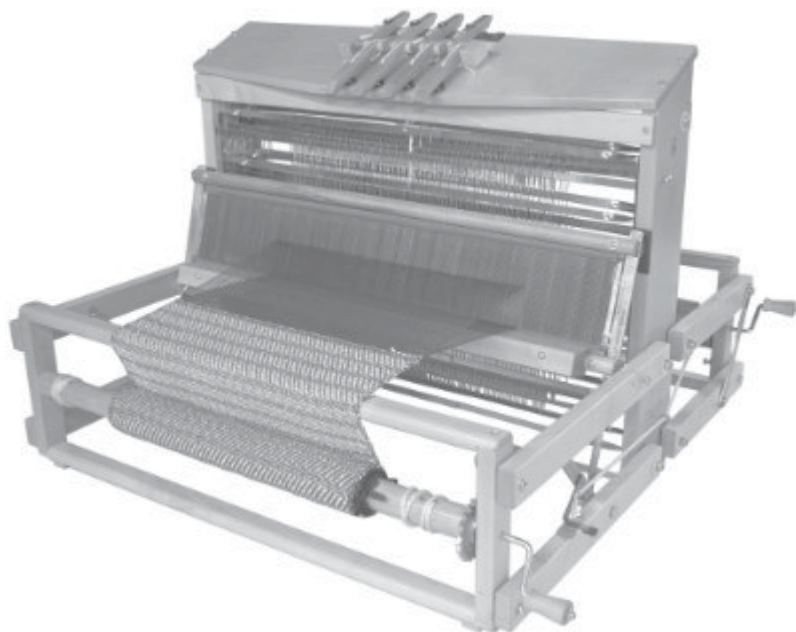

- 4s - 2124-0424 \$1492.00**
- 8s - 2124-0824 \$1665.00**
- 12s - 2124-1224 \$1815.00**
- 16s - 2124-1624 \$2269.00**

STANDARD EQUIPMENT

- » Stainless Steel Reed, 12 dents/inch
- » 1 boat shuttle 6122-0000
- » 1 reed and heddle hook 6141-7000
- » 2 metal lease sticks
- » 10 loop cords for lashing
- » Transfer heddle Bars
- » Instructions
- » Book "Warp and Weave"

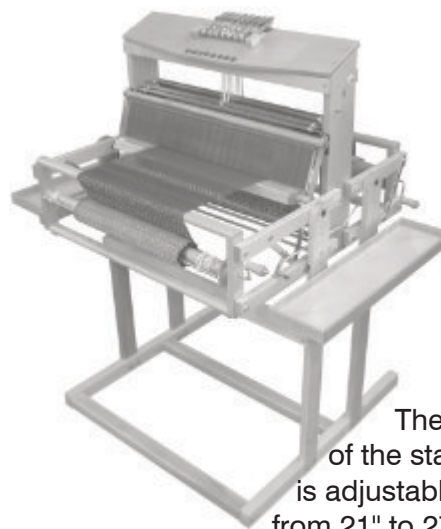
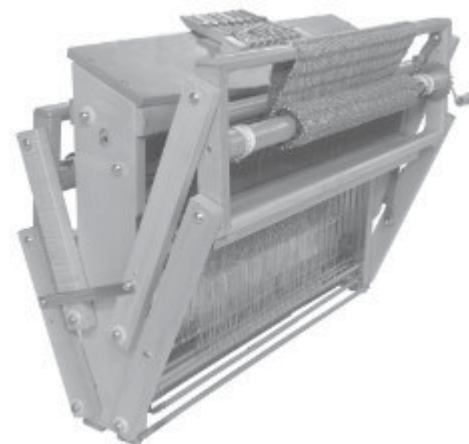

The height of the stand is adjustable from 21" to 27³/₄"

SPECIFICATIONS & DIMENSIONS

No. of shafts	4s	8s	12s	16s
Weaving width	24 ³ / ₄ " - 60 cm			
Quantity of heddles	600			
Loom width	28 ¹ / ₂ " (without the crank)			
Depth	26 ³ / ₄ "	27 ³ / ₄ "	30"	31 ¹ / ₂ "
Height	21"			
Net weight	25 lbs	29 lbs	33 lbs	39 lbs
Dimensions when folded	28.5" w 11.25" d 20.5" h	28.5" w 12.25" d 20.75 h	28.5" w 14.5" d 21" h	28.5" w 17" d 22" h
Double Warp Beam 24"	6432-1100 \$497.00			
Stand with side shelves	6313-2024 \$718.00			
Stand without side shelves	6313-2009 \$552.00			

In 1998 we at Leclerc designed and introduced the totally new concept Voyager following the demands from the field for an 8s workshop loom with front Levers and easy portability. The loom proved to be an immediate success. Following the initial 8s model, Leclerc followed with a 4s and 12s model.

Continuing our policy of leading edge technical design and development, for 2006 Leclerc introduces the 24" 4s, 8s and 12s models with features most favored by handweavers worldwide.

- Leclerc's time proven micro advance Friction Brake allowing uninterrupted weaving and cloth advance rhythm.
- A full 9 3/4" weaving space from Shafts to Breast Beam providing maximum weave time to cloth advance ratio.
- Solid Canadian Maple Castle and Frame Sides.
- A new and unique compact folding technique

In addition we have designed a matching Table with stability and functionality that allows the weaver to focus on weaving. For those who prefer even greater versatility, the Swinging Beater is also available in a Kit for **2120-0924 \$193.00** The Beaters can be interchanged in a few minutes.

DOROTHY 15³/₄

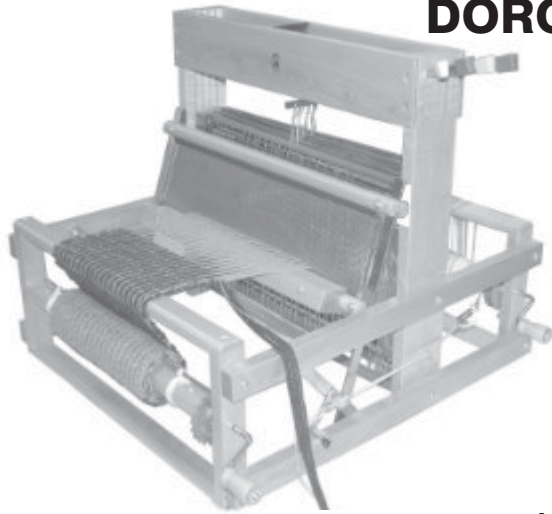

2110-0000 4 shaft \$994.00

2111-1000 8 shaft \$1356.00



STANDARD EQUIPMENT

- » Stainless Steel Reed, 12 dents/inch
- » 1 boat shuttle 6122-1000
- » 1 reed and heddle hook 6141-7000
- » 2 metal lease sticks
- » 10 loop cords for lashing
- » Transfer heddle Bars
- » Instructions
- » Book "Warp and Weave"

4 SHAFT LOOM

This 4 shaft table loom is collapsible for easy carrying and storage. It is a practical loom for schools, summer camps, occupational therapy and hobbyists. The shafts are operated by the unique side levers of graduated lengths. A 4 shaft loom comes with levers on the right. The selection of the harnesses is easy because the lever tabs are in different colors.

This 4 shaft loom can be supplied with a deeper frame to which additional 4 shaft sections can be added to convert it to 8 or even 12 shafts. All you have to do is assemble the sections as you wish: they are screwed to the frame. Levers for harness frames are permanently situated.

8 or 12 SHAFT LOOM

This Dorothy loom is built with a deeper frame in which you can place 2 or 3 sections of 4 shafts, placing levers either on the right or left hand side, as you wish but usually we alternate, right for the first, left for the second and right for the third.

TABLE FOR DOROTHY 15³/₄" 4s

Light folding base. The height (25") allows the weaver to use an ordinary chair to operate the loom.

6312-2000 \$336.00

SPECIFICATIONS & DIMENSIONS

	4 Shaft	8 Shaft	12 Shaft
Weaving width	15 ³ / ₄ " 40 cm	15 ³ / ₄ " 40 cm	15 ³ / ₄ " 40 cm
Quantity of heddles	400	400	400
Loom width	20 ¹ / ₄ " 51 cm	20 ¹ / ₄ " 51 cm	20 ¹ / ₄ " 51 cm
Depth	20 ¹ / ₂ " 52 cm	31 ¹ / ₄ " 79 cm	31 ¹ / ₄ " 79 cm
Height	17 ¹ / ₂ " 44 cm	17 ¹ / ₂ " 44 cm	17 ¹ / ₂ " 44 cm
Net weight	16 lbs 7 kg	25 lbs 11 kg	32 lbs 14 kg

OPTIONS:

- » Inserted eye or Texsolv heddles instead of wire heddles: 2110-1000 \$55.00
- » Dorothy 4 Shaft section with long crossmembers (left or right) 6392-4(3) \$567.00
- » SECOND WARP BEAM for Dorothy 6432-1001 \$475.00

DOROTHY 24" v2

STANDARD EQUIPMENT

- » Stainless Steel Reed, 12 dents/inch
- » 1 boat shuttle 6122-1000
- » 1 reed and heddle hook 6141-7000
- » 2 metal lease sticks
- » 10 loop cords for lashing
- » Transfer heddle Bars
- » Instructions
- » Book "Warp and Weave"



2410-0000 4 shaft \$1305.00
2411-0008 8 shaft \$1930.00



Height adjustable:
 20"
 22.5"
 24.5"
 27"

STAND WITH SIDE SHELVES FOR DOROTHY 4s 24"
 A stand to convert your Dorothy 24" into a foot-powered loom.
4 shaft loomstand with 6 treadles
6313-2000 \$903.00

4 or 8s loom stand without treadles
6313-2008 \$718.00

Same stand without the shelves
 6313-2009 - \$552.00

SPECIFICATIONS & DIMENSIONS

	4 Shaft	8 Shaft
Weaving width	24" 60 cm	24" 60 cm
Quantity of heddles	600	600
Loom width	28" 71 cm	28" 71 cm
Depth	25" 64 cm	29" 74 cm
Height	21 1/2" 54 cm	21 1/2" 54 cm
Net weight	22 lbs 10 kg	30 lbs 14 kg

OPTIONS

- » Inserted eye or texsolv heddles instead of wire heddles: 2110-1024 \$ 70.00
- » Dorothy 4 Shaft section left (or right) with longer frame parts 6392-5(6) \$582.00
- » SECOND WARP BEAM for Dorothy 6432-1100 \$497.00
- » Sectional Warp Beam for Dorothy 24" (23 x sections of 1") 6443-1100 \$516.00



DIANA 24" - 16 SHAFT - COMPUTER-DOBBY

This new 16 Shaft Loom is designed to operate either as a Table model or, with our matching 2 Treadle Base, as a floor model. The unit will operate with MAC or PC Software.

The Table top model is designed with the Operating Handle in the front of the loom. The Operating Handle lifts the shafts and locks the shed open freeing both hands to operate the loom. The Operating Handle is then lowered changing the shed to the next pick position and completing the cycle.

The Floor model is designed to operate with two treadles. The right treadle lifts the shafts to open the shed. The left treadle assists the return of the shafts to neutral and controls the pattern advance.

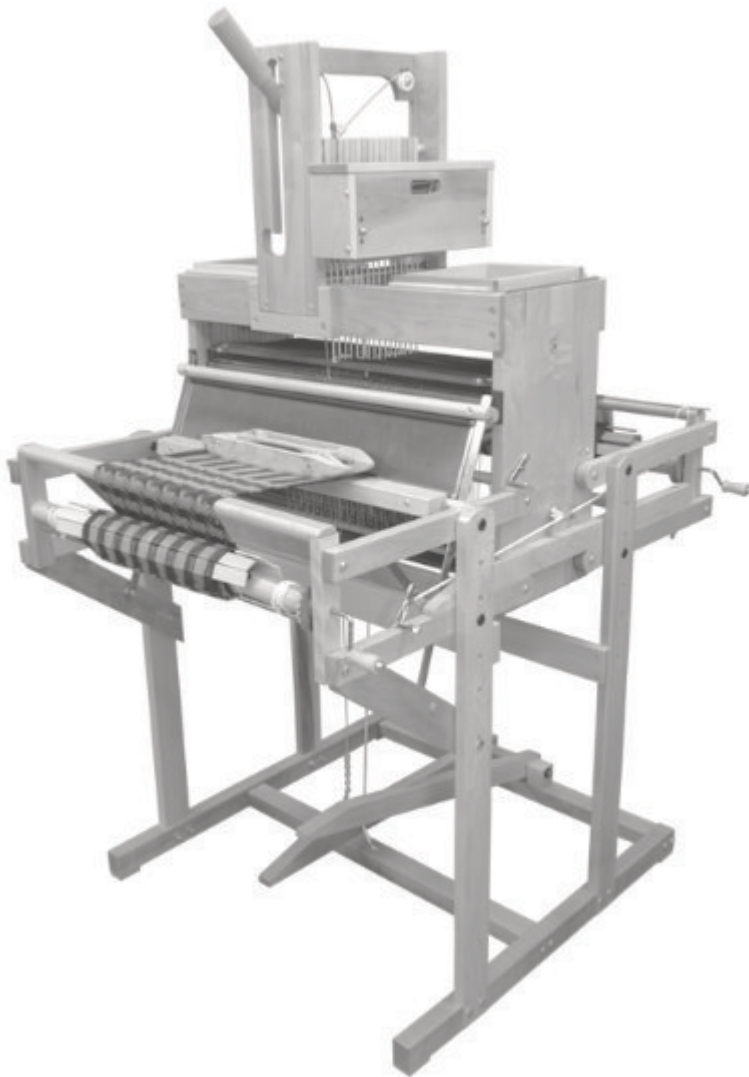

STANDARD EQUIPMENT

- » Stainless Steel Reed, 12 dents/inch
- » 2 Head trays
- » 1000 inserted eye heddles (9½")
- » 1 boat shuttle 6122-1000
- » 1 reed and heddle hook 6141-7000
- » 10 loop cords for lashing
- » 2 metal rods
- » Stringing loop cord
- » Instructions, Video
- » Book "Warp and Weave"

SPECIFICATIONS

Weaving width: 24"
Loom width: 28"
Loom depth: 36"
Loom height: 31½"
Dimensions when folded: 28"w, 20"d, 31"h

STAND SPECIFICATIONS

Stand Height: 26"
Height between floor
and cloth beam : 29"
Net weight of loom with stand: 55 lbs

2120-1624

**Complete loom with stand and the
Electronic Interface box \$ 6198.00**

Sectional Warp Beam (same as Dorothy 24")
(23 x sections of 1") 6443-1100 \$516.00

COMPACT 24"



All looms include free
Wheels on the 4 posts

STANDARD EQUIPMENT

- » Stainless Steel Reed, 12 dents/inch
- » 10½" (26.8 cm) wire heddles
- » 1 boat shuttle 6122-1000
- » 1 reed and heddle hook 6141-7000
- » 2 lease sticks and 2 warp rods
- » 10 loop cords for lashing
- » Assembly instructions and Video
- » Book "Warp and Weave"

24" Weaving Width

This jack-type floor loom is light but solid and easily moveable when folded. It is designed for workshops and demonstrations. To fold, slightly unscrew the two handles on the sides of the loom and slide them up. It can be folded easily even after weaving has started. The Compact loom is built with six treadles for easy tie-up, and can be converted into an 8 shaft loom, by adding 4 shafts (and 4 treadles). It is equipped with a 1 7/8" (4 cm) regular plain beam, to which a set of rake-like pieces (sectional warp beam) can be added. The rake-like pieces must be screwed directly on the beam. Without an extension, the circumference of the sectional warp beam is 15" (38 cm).

SPECIFICATIONS & DIMENSIONS

Number of heddles	600
Loom width (outside)	32" 81 cm
Depth opened	35" 89 cm
Depth folded	21" 54 cm
Height front	29½" 75 cm
Height opened	36½" 93 cm
Height closed	36½" 93 cm
Front height	29½" 75 cm
Net Weight	72 lbs 32 kg
Shipping weight	84 lbs 38 kg

4 SHAFT 1022-0000 \$2409.00
8 SHAFT 1022-0001 \$3355.00

OPTIONS

- | | | |
|--|-----------|----------|
| » Kit: 4 Extra Shaft Kit | 1023-0000 | \$820.00 |
| » Inserted eye or Texsolv heddles instead of wire heddles: | 1022-9800 | \$77.00 |
| » Compact Double Back Beam | 1057-0000 | \$518.00 |
| » Sectional Warp Beam 1" (25 mm) Sections | 6443-3000 | \$393.00 |
| » Bench (adjustable in height) | 6384-6000 | \$407.00 |
| » Wheels Kit (4) for previous version | 1023-0001 | \$179.00 |



ARTISAT 36"



Jack-Type 4 Shaft

1009-0000 Jack-Type 4 Shaft Loom \$2904.00
1009-0008 Jack-Type 8 Shaft Loom \$4111.00



4s loom folded

This 4 shaft jack-type floor loom is designed for the weaver with limited space who wants a fairly wide, solid loom. The Artisat is a quiet floor model loom equipped with an easy tie-up system. Loom weight has been reduced to a minimum, but it is sufficiently sturdy to do heavy work. It can be folded front and back to a depth of 14" (4 shaft loom) even if weaving is on the loom. The shed will always be good regardless of the kind of cloth you are making (Double Weave, Bronson, Leno, etc.). It is built with 6 treadles (4 shaft loom) and permits any combination of tie-ups. Equipped with a regular plain beam, a set of rake-like pieces may be added to convert it into a sectional warp beam. The rake-like pieces must be screwed directly onto the beam. Extensions can be added to increase the sectional beam circumference.

ARTISAT 36" JACK-TYPE LOOM WITH BACK HINGE TREADLES

As with all Loom designs there are some tradeoffs. With the Jack Loom the problem most often cited was the difficulty in getting a good shed with 6+ Shaft weave construction. Our new design has overcome this problem .

The new design features the Treadles anchored at the rear of the Loom, with a new, unique, Rocker mechanism that insures even tension on all Treadle Cords with the Treadles in both the rest or depressed position.

This new design provides the weaver with the ease of Leg Treadling multi Shaft designs, comparable to that of a 4 shaft. In addition, a wide, clean shed is obtained on all Shafts.

By following a new procedure, the new Treadle design retains the folding feature designed into the original Artisat.

**1009-3628 Artisat 36"
8s Back Hinge Treadles loom \$4174.00**

**1009-2836 Kit 4 More Shaft
with Back Hinge Treadles \$2942.00**

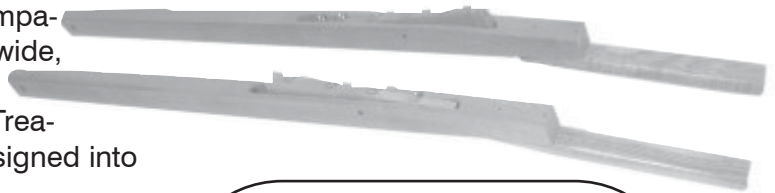

**BACK HINGE TREADLE KIT
FOR EXISTING ARTISAT 8
SHAFT LOOM 1009-2936
\$1302.00**



See next page for Equipment,
Dimensions and Options



ARTISAT 36"

STANDARD EQUIPMENT

- » 6 treadles
- » Stainless Steel Reed, 12 dents/inch
- » Wire heddles, 10½" (26,8 cm)
- » 1 boat shuttle 11¾" 6122-3000
- » 1 doz. plastic bobbins 6133-6000
- » 1 reed & heddle hook 6141-7000
- » 1 apron
- » 2 lease sticks
- » 2 warp rods
- » 2 beam sticks
- » 2 cords
- » Book: "Warp and Weave"
- » Assembly instructions

SPECIFICATIONS & DIMENSIONS

	4s loom	8s loom
Weaving width	36" 90 cm	
Number of Heddles	1000	
Loom Width	46" 117 cm	
Depth Opened	32" 80 cm	43" 107cm
Depth Folded	14" 36 cm	17" 43 cm
Front Height	30¾" 78 cm	
Net Weight	95 lbs 43 kg	135 lbs 61 kg

OPTIONS

Extra charge for inserted eye (or texsolv) heddles instead of wire heddles	1009-1100	\$128.00
Adjustable Bench 21" - 25" height	6384-6000	\$407.00
Open ended Bench 23" high	6384-2000	\$834.00
Sectional warp beam 1" sections	6441-4000	\$392.00
Double warp beam	6431-4000	\$846.00

Kit to transform a regular 4 shaft jack loom to 8 shaft jack with back hinge treadles	1009-2836	\$3070.00
Kit to transform an existing 8 shaft jack loom to 8 shaft jack with back hinge treadles	1009-2936	\$1360.00



MIRA II

27", 36", 45" and 60" with Shed Regulator



STANDARD EQUIPMENT

- » Stainless Steel Reed, 12 dents/inch
- » 10½" (26.8 cm) wire heddles
- » 1 boat shuttle 6122-3000
- » 1 reed and heddle hook 6141-7000
- » 2 lease sticks and 4 warp rods
- » 2 cords
- » 2 aprons
- » Assembly instructions and Video
- » Book "Warp and Weave"

4230-0127	27"	\$4071.00
4230-0136	36"	\$4071.00
4230-0145	45"	\$4320.00
4230-0160	60"	\$4879.00

SPECIFICATIONS & DIMENSIONS			
Weaving width	36" 90 cm	45" 115 cm	60" 150 cm
Quantity of heddles	1000	1200	1500
Depth	39" 99 cm		
Loom width	46" 117 cm	55" 140 cm	70" 170 cm
Total height	58" 132 cm		
Breastbeam height	31¼" 79 cm		
Distance between the reed and the breastbeam	13" 33 cm		
Net weight	113 lbs 51 kg	124 lbs 56 kg	150 lbs 68 Kg

A counter-balanced 4 shaft loom, with a sturdy, rigid frame, that makes it especially useful for teaching, commercial production studio or rug weaving. You can speed-up the production by adding the flying shuttle beater.

The new Mira II model looms incorporate Leclerc's **exclusive Shed Regulator**. This unique mechanism provides a quick simple switch from balanced to unbalanced weaves with a minimum of adjustment. This provides the same versatility as a Jack Loom but with the advantage of full control over top and bottom Shed openings offered by the Counterbalance design.

The Counterbalance Shed is wide and clean on every pick over the full range of 4 Shaft weaves, including the higher tension Rug designs.

Solidly constructed out of maple, this loom has a friction brake, and easily removeable cloth and breast beams. All metal parts are plated and the top rollers are adjustable in height. A sectional warp beam can be installed at any time.

For Options, see Page 20

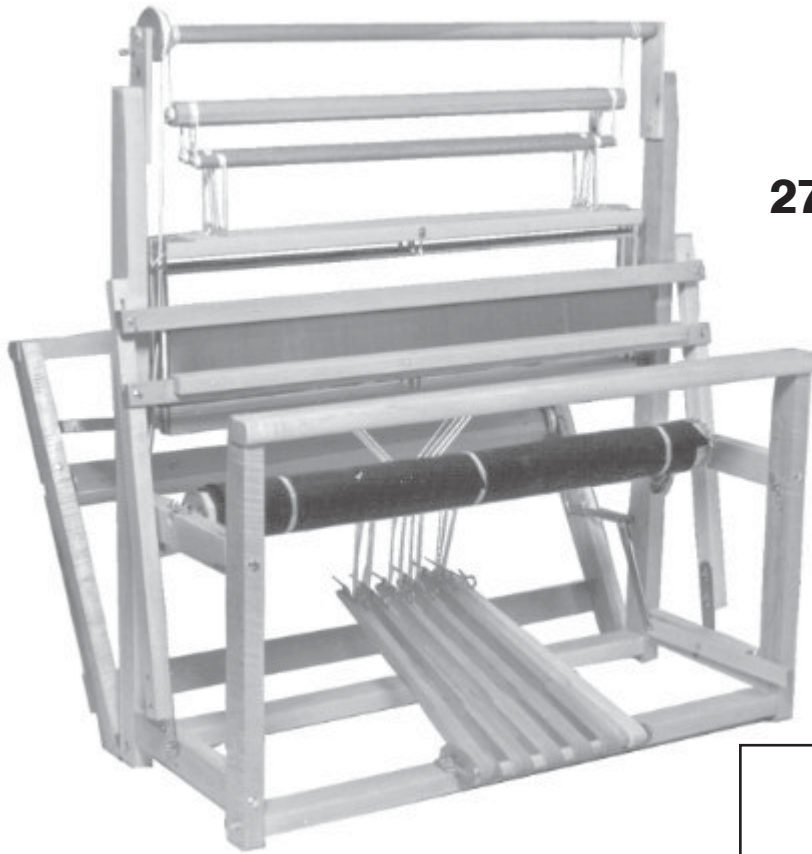

FANNY II **27" 36", 45" and 60"** **with Shed Regulator**

1024-0127	27"	\$4071.00
1024-0136	36"	\$4071.00
1024-0145	45"	\$4320.00
1024-0160	60"	\$4879.00

Leclerc's 4 Shaft Counterbalance "Fanny" model Looms have been a favourite of Handweavers for over 60 years. There are literally hundreds in operation throughout North America and around the world.

STANDARD EQUIPMENT

- » Stainless Steel Reed, 12 dents/inch
- » 10½" (26.8 cm) wire heddles
- » 1 boat shuttle 6122-3000
- » 1 reed and heddle hook 6141-7000
- » 2 lease sticks and 4 warp rods
- » 2 cords
- » 2 aprons
- » Assembly instructions and Video
- » Book "Warp and Weave"

Due to the ease of Treadle reach, the "Fanny" is favoured by the average weaver for comfort over long weaving sessions. Leclerc's compact, solid design allows weaving a full range of Fabric including Rugs. With that, Leclerc decided to enhance the overall weaveability by introducing the "Fanny II".

All "Fanny II" model Looms incorporate Leclerc's exclusive Shed Regulator. This unique mechanism provides a quick simple switch from balanced to unbalanced weaves with a minimum of adjustment. This provides the same versatility as a Jack Loom but with the advantage of full control over top and bottom Shed openings offered by the Counterbalance design. The Counterbalance Shed is wide and clean on every pick over the full range of 4 Shaft weaves, including the higher tension Rug designs.

For weaving a full range of 4 Shaft Fabrics, the "FANNY II" is the choice for price and performance.

FANNY II

36", 45" and 60"

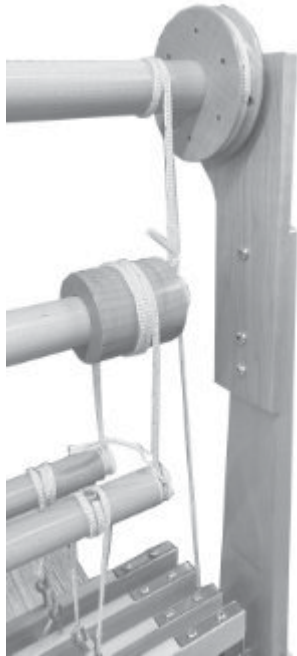

SPECIFICATIONS & DIMENSIONS			
Weaving width	36" 90 cm	45" 115 cm	60" 150 cm
Quantity of heddles	1000	1200	1500
Depth opened	36½" 93 cm		
Depth closed	25" 63 cm		
Loom width	46" 117 cm	55" 140 cm	70" 170 cm
Total height	58½" 149 cm		
Breastbeam height	31¼" 79 cm		
Distance between the reed and the front breastbeam	13" 33 cm		
Net weight	118 lbs 53 kg	130 lbs 59 kg	158 lbs 72 Kg

Mira II and Fanny II options			
Largeur de tissage	36" 90 cm	45" 115 cm	60" 150 cm
Inserted eye heddles or texsolv	1024-9836 \$125.00	1024-9845 \$143.00	1024-9860 \$189.00
Bench with open ends 23"	6384-2000 \$834.00		
Sectional warp beam 1" section	6441-4000 \$392.00	6441-5000 \$480.00	6441-6000 \$605.00

NILUS 27", 36", 45" and 60"

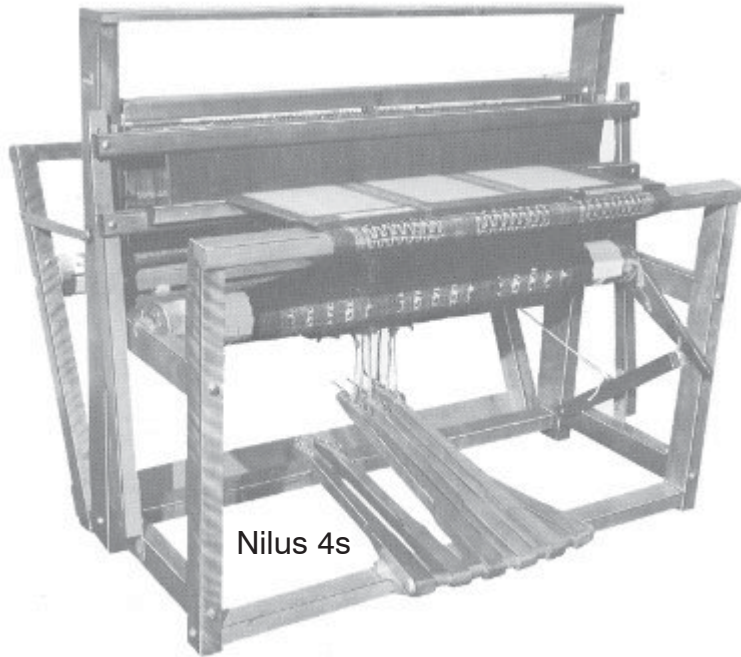

STANDARD EQUIPMENT

- » Stainless Steel Reed, 12 dents/inch
- » 10½" (26.8 cm) wire heddles
- » 1 boat shuttle 6122-3000
- » 1 reed and heddle hook 6141-7000
- » 2 lease sticks
- » 4 warp rods
- » 2 cords
- » 2 aprons
- » Assembly instructions and Video
- » Book "Warp and Weave"

JACK-TYPE LOOM LOW CASTLE

A sturdy 4-shaft jack-type loom that folds to a depth of 25" (63 cm). A loom with independent shafts is ideal for weaving any type of fiber. The Nilus is one of the most popular models, and includes a friction brake and removable front and back beam.

	4s loom	8s with Back Hinge Treadles
27"	1025-0027 \$4196.00	1025-2728 \$5432.00
36"	1025-0036 \$4196.00	1025-3628 \$5432.00
45"	1025-0045 \$4444.00	1025-4528 \$5697.00
60"	1025-0060 \$5190.00	1025-6028 \$6575.00

NILUS 36", 45" and 60"



Nilus 8s
Standard
Front Hinge Treadles



Nilus 8s
Back Hinge Treadles

SPECIFICATIONS & DIMENSIONS			
Weaving width	36" 90 cm	45" 115 cm	60" 150 cm
Quantity of heddles	1000	1200	1500
Depth opened	4s = 40" 102 cm / 8s = 43" 109 cm		
Depth closed	4s = 25" 63 cm / 8s = 28" 71 cm		
Loom width	46" 117 cm	55" 140 cm	70" 170 cm
Total height	45" 114 cm		
Breastbeam height	31¼" 79 cm		
Distance between the reed and the front breastbeam	13" 33 cm		
Net weight 4s loom	118 lbs 53 kg	130 lbs 59 kg	158 lbs 72 kg
Net weight 8s loom	138 lbs 76 kg	175 lbs 79 kg	203 lbs 92 kg

OPTIONS			
Weaving width	36" 90 cm	45" 115 cm	60" 150 cm
Inserted eye heddles or texsolv	1024-9836 \$125.00	1024-9845 \$143.00	1024-9860 \$189.00
Bench with open ends 23"	6384-2000 \$834.00		
Sectional warp beam 1" section	6441-4000 \$393.00	6441-5000 \$480.00	6441-6000 \$605.00
Kit to transform a 4s loom to an 8s with back hinge treadles	1025-2836 \$3404.00	1025-2845 \$3878.00	1025-2860 \$4606.00
Kit 4s loom to an 8s loom front hinge treadles	1025-2736 \$3279.00	1025-2745 \$3752.00	1025-2760 \$4481.00



NILUS II 36", 45" 60" and 72"

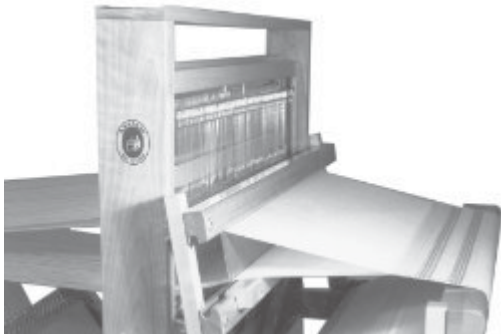

Nilus II 4s folded

Counter-balance
Nilus II

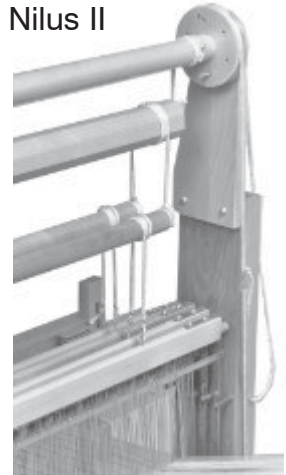

MODEL: JACK-TYPE

36"	1029-0000	4 Shaft Loom	\$4196.00
45"	1030-0000	4 Shaft Loom	\$4444.00
60"	1031-0000	4 Shaft Loom	\$5066.00

MODEL: COUNTER-BALANCE

36"	1026-0000	4 Shaft Loom	\$4196.00
45"	1027-0000	4 Shaft Loom	\$4444.00
60"	1028-0000	4 Shaft Loom	\$5066.00

72" 1028-0072 4 Shaft Loom

With 2 set of treadles and 2 brake system: \$7582.00

MODEL: 8 SHAFT JACK-TYPE

36"	1029-0008	8 Shaft Loom	\$4817.00
45"	1030-0008	8 Shaft Loom	\$5593.00
60"	1031-0008	8 Shaft Loom	\$6209.00

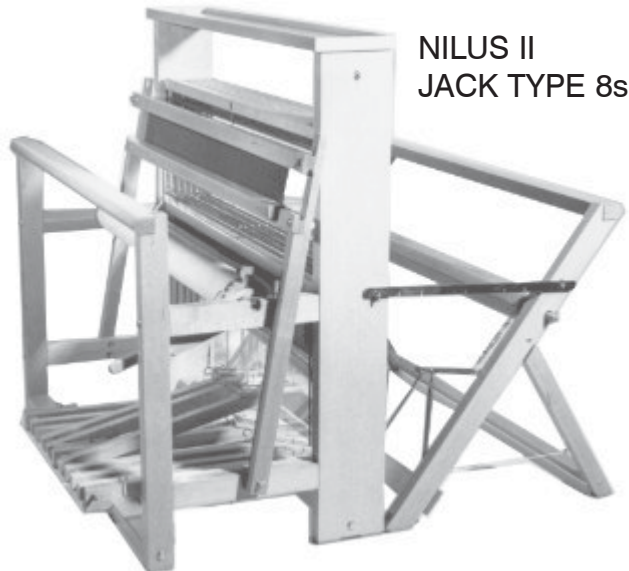

NILUS II
JACK TYPE 8s

(Counter-balanced, Jack-type or Jack-type with back hinge treadles)

The Nilus II 4s is available in two versions- Jack or counterbalance. The 8s loom is available in 3 versions - Jack, Jack with Back Hinge Treadles and Countermarche. The Nilus II loom has been designed with a stabilizer foot, for better stability. The shed is always good with any tie-up combination. The counter-balanced version is built with an integrated shed regulator, so it is possible to weave any kind of material. On the jack-type version, the top can be easily removed, allowing easy access to the shafts for the addition or removal of heddles. Heddles used are 12½" (31.7 cm) long. It is a loom with independent shafts, guided by pegs at each side, preventing friction of the frames which are pushed upwards by an underneath mechanism. All Nilus II looms have non-sliding polyvinyl foot pads under the uprights to keep it solid on the floor. It is equipped with a friction brake giving perfect tension every time. The front cloth beam and back thread beam are removable for easy threading, and the warp beam is also removable for outside beaming when required. All looms are equipped with a regular plain beam to which a set of rake-like pieces can be added to convert it into a sectional warp beam. Special kits have been designed to convert the regular 4 shaft jack-type into an 8 shaft jack-type loom. A new back hinge treadle kit is also available. Any Nilus II 8 shaft can be upgraded to a back hinge treadle loom.

See page 26 for Equipment, Dimensions and Options

NILUS II 36", 45" and 60" JACK-TYPE WITH BACK HINGE TREADLES

As with all Loom designs there are some trade-offs. With the Jack Loom the problem most often cited was the difficulty in getting a good shed with 6+ Shaft weave construction. Our new design has overcome this problem.

The new design features the Treadles anchored at the rear of the Loom, with a new unique, Rocker mechanism that insures even tension on all Treadle Cords with the Treadles in both the rest or depressed position.

This new design provides the weaver with the ease of Leg Treadling multi Shaft designs, comparable to that of a 4 shaft.

In addition, a wide, clean shed is obtained on all Shafts. Using a new procedure, the new Treadle design retains the folding feature designed into the original Nilus II.

We, at Leclerc, are very excited about this new Jack Loom Treadling concept. This system is also available on the Nilus and Artisat loom.



	8s LOOM WITH BACK HINGE TREADLES	KIT 4 MORE SHAFT WITH BACK HINGE TREADLES	BACK HINGE TREADLES KIT FOR EXISTING NUII 8S	BACK HINGE TREADLES KIT FOR EX- ISTING NUII 4S
36"	1029-3628 \$5432.00	1029-2836 \$3077.00	1029-3036 \$1275.00	1029-4036 \$1026.00
45"	1030-4528 \$5845.00	1030-2845 \$3505.00	1030-3045 \$1387.00	1030-4045 \$1137.00
60"	1031-6028 \$6650.00	1031-286 \$4164.00	1031-3060 \$1511.00	1031-4060 \$1193.00



See page 26 for Equipment, Dimensions and Options



NILUS II 36", 45" and 60" COUNTERMARCHÉ BACK HINGE TREADLES

Our countermarche system has only one set of lams, two sets of pulleys above the shafts and one set of pulleys below. In a countermarche loom, every shaft is actively involved in each shed: each shaft is either lifted or pulled down by each pedal. Uneven sheds like 3 shafts against 1 are always large and clean. Because you actually lift or pull down every shaft, you never have any problem with one shaft floating when it should not. More details are in our technical report page 4.

**TIE-UP SYSTEM
WITH LOOP CORD
(EASY AND FAST)**

**PRE-ADJUSTED
CABLES,
NO ADJUSTMENT
TO DO.**



NILUS II 8S COUNTERMARCHÉ LOOM BACK HINGE TREADLES

36"	1029-0018	\$6464.00
45"	1030-0018	\$6918.00
60"	1031-0018	\$7943.00

See page 26 for Equipment, Dimensions and Options

NILUS II (INFORMATION FOR ALL 4 MODELS)

STANDARD EQUIPMENT

- » 6 treadles
- » Stainless Steel Reed, 12 dents/inch
- » Wire heddles, 12½" (31,7 cm)
- » 1 boat shuttle 11¾" 6122-3000
- » 1 doz. plastic bobbins 6133-6000
- » 1 reed & heddle hook 6141-7000
- » 2 lease sticks
- » 4 warp rods
- » 2 cords
- » 2 aprons
- » Book: "Warp and Weave"
- » Assembly instructions

SPECIFICATIONS & DIMENSIONS

SPECIFICATIONS & DIMENSIONS			
Weaving width	36" 90 cm	45" 115 cm	60" 150 cm
Quantity of heddles	1000	1200	1500
Depth opened	4s = 51" 130 cm / 8s = 54" 137 cm		
Depth closed	4s = 28½" 70 cm / 8s = 32" 81 cm		
Loom width	46" 117 cm	55" 140 cm	70" 170 cm
Total height	Jack type = 49" 125cm CB = 58½" 149 cm		
Breastbeam height	31½" 87 cm		
Distance between the reed and the front breastbeam	13" 33 cm		
Net weight 4s loom	155 lbs 70 kg	170 lbs 77 kg	158 lbs 72 kg
Net weight 8s loom	190 lbs 86 kg	205 lbs 93 kg	250 lbs 113 kg

OPTIONS

OPTIONS				
Weaving width	36" 90 cm	45" 115 cm	60" 150 cm	72" 183 cm
Inserted eye heddles or texsolv	1024-9836 \$125.00	1024-9845 \$143.00	1024-9860 \$189.00	1031-9872 \$242.00
Bench with open ends 26"	6384-4000 \$906.00			
Sectional warp beam 1" section	6441-4000 \$393.00	6441-5000 \$480.00	6441-6000 \$605.00	6441-6720 \$736.00



COLONIAL v2

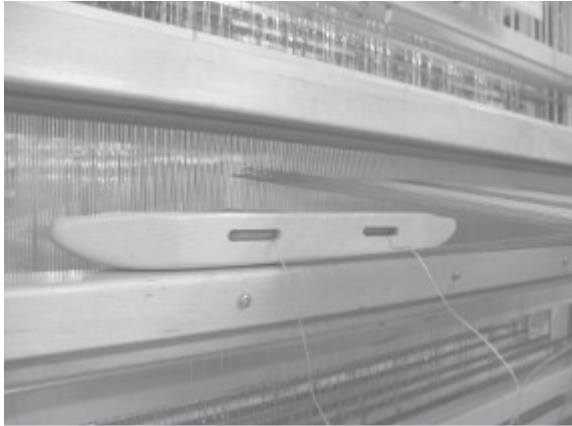

BACK HINGE TREADLE				
	45"		60"	
8 CADRES	1051-0082	\$7400.00	1052-0082	\$8134.00
12 CADRES	1051-0212	\$8260.00	1052-0212	\$9209.20

A loom reminiscent of those our ancestors used, with many major improvements which makes this one of the best Leclerc looms ever produced. Its great adaptability allows it to be used as a general purpose loom, or for any specific purpose required by an inventive and creative weaver.

Made of the finest Canadian maple, it is finished with clear lacquer and varnish so that the beauty of the natural grain and color of the lumber remains visible. Because the jacks are in the loom castle, less pressure is needed to lift the shafts.

The overhead beater is optional.

- Wider and cleaner shed
- The Back Hinge Treadle is easier treading
- Jacks now ride on bushings
- The tie-ups system reduces the time and minimizes the concurrence of cord mix-up.



COLONIAL v2 45" or 60"

STANDARD EQUIPMENT

- | | |
|---|---|
| <ul style="list-style-type: none"> » 10 or 14 treadles » Stainless Steel Reed, 12 dents/inch » Wire heddles, 12½" (31,7 cm) » 1 boat shuttle 11¾" 6122-3000 » 1 doz. plastic bobbins 6133-6000 » 1 reed & heddle hook 6141-7000 | <ul style="list-style-type: none"> » 2 lease sticks » 4 warp rods » 2 cords » Book: "Warp and Weave" » Assembly instructions |
|---|---|

SPECIFICATION AND DIMENSIONS

SPECIFICATION AND DIMENSIONS		
Weaving width	45" 115 cm	60" 150 cm
Quantity of heddles	1200	1500
Depth opened	53" 135 cm	
Loom width	57" 145 cm	72" 183 cm
Total height	68" 173 cm	
Breastbeam height	34½"	
Distance between the reed and the front breastbeam	14" 35.5 cm	
Net weight 8s loom	205 lbs 93 kg	221 lbs 100 kg
Net weight 12s loom	298 lbs 135 kg	310 lbs 140 kg

OPTIONS

OPTIONS		
Weaving width	45" 115 cm	60" 150 cm
Inserted eye heddles or texsolv	1051-9800 \$149.00	1052-9860 \$198.00
Bench with open ends 26"	6384-4000 \$906.00	
Sectional warp beam 1" section	6441-5000 \$480.00	6441-6000 \$605.00

Weavebird v2

16, 24 & 32 shafts, 27" 36" 45" 60" & 72"

Weavebird is a centre closed dobby shedding mechanism. There are no jacks, no lams, no tie ups, no limitations on shaft combinations http://www.leclerclooms.com/cat_leus/US27_28.pdf and no limitations of pattern repeats.

Two treadles, hinged from the back of the loom, operate the shedding mechanism. Weavebird controls the rising and sinking shed so the tension on the warp threads is always uniformly even. Because part of the warp threads rise while the balance sink, the yarn stretch is minimized. The loom has 2 treadles. The right treadle opens the shed and the left treadle closes it. Due to Leclerc's unique Shaft counter-weight design, physical stress to operate it is minimized.

The treading effort to operate those Loom is similar to operating a 4 shaft counterbalance loom.



SPECIFICATIONS AND DIMENSIONS

Weaving width	27" (68 cm)		36" (90 cm)			45" (115 cm)			60" (150 cm)		
	16s	24s	16s	24s	32s	16s	24s	32s	16s	24s	32s
Number of heddles	1000	1500	1500	2000	2500	2000	2500	3000	2500	3000	3500
Loom width	44" / 111 cm		50½" - 128 cm			59½" - 151 cm			74½" - 189 cm		
Loom depth	61" / 155 cm	66" / 168 cm	61" / 155 cm	66" / 168 cm	71" / 180 cm	61" / 155 cm	66" / 168 cm	71" / 180 cm	61" / 155 cm	66" / 168 cm	71" / 180 cm
Loom height	68" - 173 cm										
Front height	34½" - 87 cm										
Net weight (app.)	200 lbs / 91 kg	240 lbs / 109 kg	240 lbs / 109 kg	280 lbs / 127 kg	310 lbs / 140 kg	280 lbs / 127 kg	330 lbs / 150 kg	360 lbs / 163 kg	320 lbs / 145 kg	385 lbs / 175 kg	410 lbs / 185 kg

WEAVEBIRD 16, 24 or 32s COMPUTER DOBBY WITH INTERFACE BOX

	27"	36"	45"	60"	72"
16s loom	1016-2700 \$11124.00	1016-3600 \$11124.00	1016-4500 \$11480.00	1016-6000 \$12575.00	1016-7200 \$16588.00
24s loom		1024-3600 \$13977.00	1024-4500 \$14509.00	1024-6000 \$15839.00	
32s loom		1032-3600 \$16817.00	1032-4500 \$17611.00	1032-6000 \$18717.00	
		Overhead Beater 6395-9000		\$406.00	



“WEAVEBIRD” 27", 36", 45" or 60" 16, 24 or 32S

STANDARD EQUIPMENT

- » **Interface Box**
- » 1 Stainless Steel Reed 6, 8, 10 or 12 dents per inch
- » Inserted Eye Heddles 12½" or Texsolv
- » 1 End Feed Shuttle 6122-8000
- » 12 Pirns 6¼" 6133-6000
- » 1 Reed & Heddles Hooks 10 5/8" long 6140-1000
- » 2 Wood lease sticks
- » 4 Warp rods
- » Book: "Warp & Weave"
- » Assembly Instruction and Video
- » Aprons
- » 2 Years Warranty on all parts including the Interface box and Solenoids
- » Do not include any software and driver

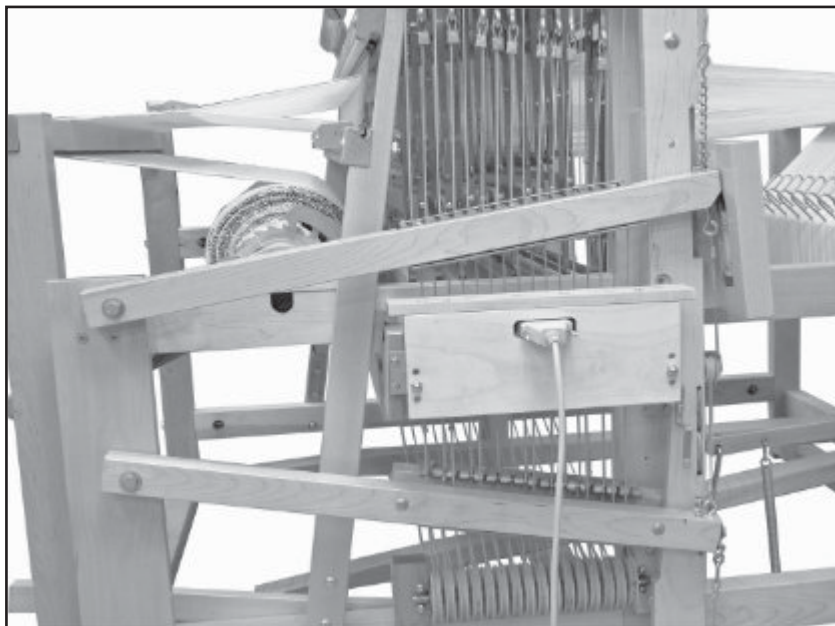

OPTIONS			
Weaving width	36" 90 cm	45" 115 cm	60" 150 cm
Sectional warp beam 1" section	6441-4000 \$392.00	6441-5000 \$480.00	6441-6000 \$605.00
Bench with open ends 26"	6384-4000 \$906.00		



KEBEC II 100", 120"

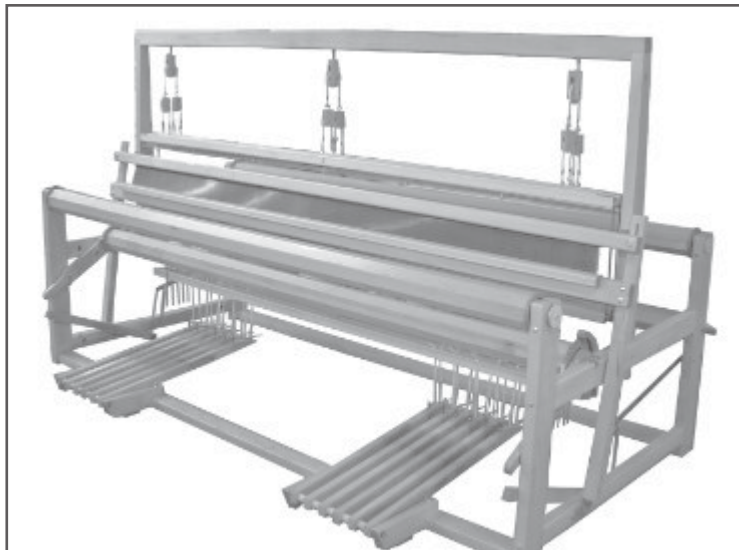

Kebec II is a strongly built 4 shaft counter-balance loom, allowing the production of wide fabrics. It is operated by two weavers, each one working with his own set of treadles, and throwing or receiving the shuttle in turn. With the flying shuttle beater, it can also be operated by one person. The loom is provided with floating lams; neither end of the lams are affixed to the loom frame. This makes the threading easier. It is always equipped with treadle sets fixed in front. Whichever treadle is used, the tension remains the same and the shed is perfect from one end to the other.

PERFECT LOOM FOR: BLANKETS, TABLE CLOTHS, DRAPERIES, COVERLETS, BED SPREADS AND RUGS

100" 1003-0000 \$12493.00
120" 1004-0000 \$13535.00

STANDARD EQUIPMENT

- » Steel reed, 6, 8, 10 OR 12 dents/inch
- » Wire heddles 12½" (31.7 cm)
- » 2 boat shuttles 15¾" 6122-2000
- » 1 doz. plastic bobbins 6133-8000
- » 1 reed and heddle hook 6141-7000
- » 2 lease sticks
- » 4 warp rods
- » 2 cords
- » 2 aprons
- » Assembling instructions
- » Book "Warp and Weave"

SPECIFICATION & DIMENSIONS

	100" 250 cm	120" 300 cm
Largeur de tissage	100" 250 cm	120" 300 cm
Quantité d'aiguilles	2500	3000
Profondeur	49" 125 cm	
Largeur totale	112" 285 cm	133" 337 cm
Hauteur	63" 180 cm	
Hauteur poitrine avant	34" 86 cm	
Distance entre le ros et la poitrine	14" 35.5 cm	
Pois net 8 cadres	325 lbs 147 kg	370 lbs 167 kg

OPTIONS

	45" 115 cm	60" 150 cm
Largeur de tissage	45" 115 cm	60" 150 cm
Aiguille oillet inséré ou texsol	1051-9800 \$325.00	1052-9860 \$391.00
Banc bout ouvert 26"	6384-4000 \$906.00	
Ensemble ourdissoir section de 1"	6441-7000 \$874.00	6441-8000 \$1196.00



CENDREL: INKLE LOOM - WARPING FRAME



STANDARD EQUIPMENT

- » 1 flat shuttle 6"
- » 1 flat shuttle 10"
- » 17 round pegs
- » 1 slot peg
- » 1 flat peg
- » Assembly instructions

SPECIFICATIONS

- » Height: 32³/₄" (83 cm)
- » Width: 28¹/₂" (72 cm)
- » Depth: 14" (36 cm)
- » Net Weight: 9 lbs (4.1 kg)

3310-0000 \$374.00

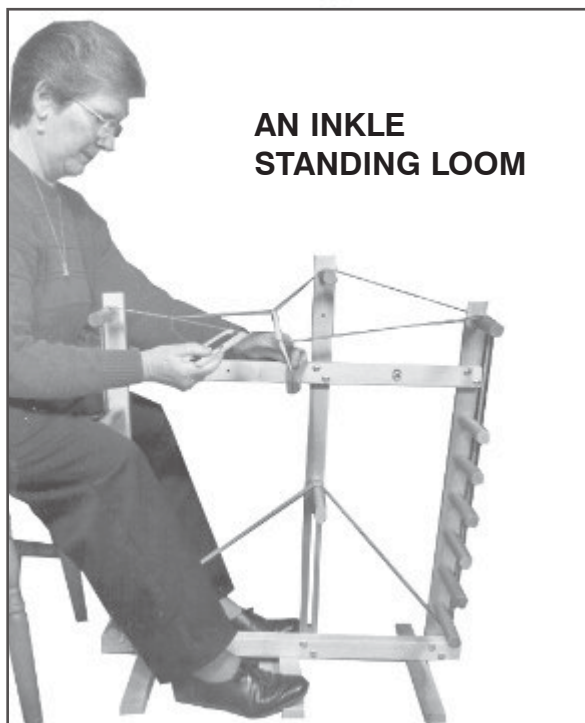

**AN INKLE
STANDING LOOM**

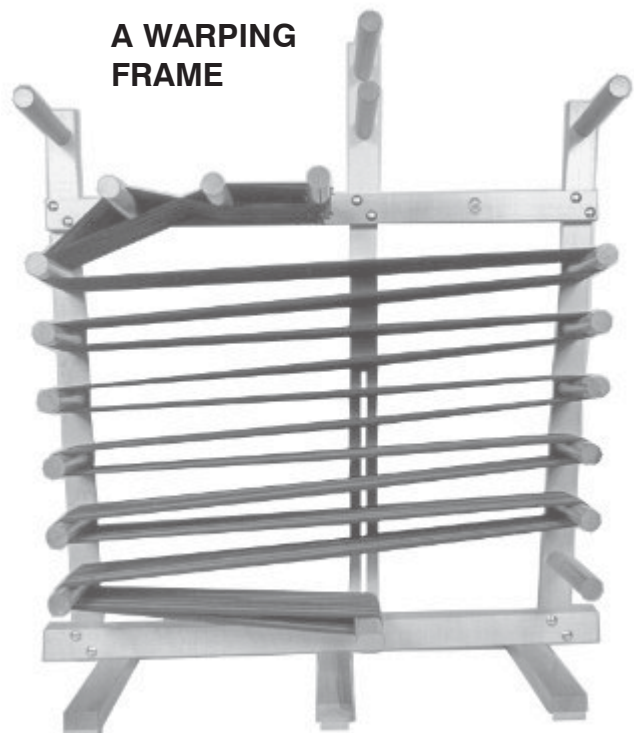

**A WARPING
FRAME**

A floor standing INKLE Loom, to weave strips of fabric up to 6" wide and 16 feet long. Designed for continuous string heddles which are made in minutes. The heddle length is adjustable by turning the heddle carrier. The weaving is swift, quiet and colorful. Useful articles, such as belts, ties, guitar straps, tray-holders, etc., can be completed in an hour's weaving time. Strips can be joined for cushions, wall-hangings.

The CENDREL can be converted to an efficient warping frame with the supplied warping pegs. It then becomes one of the basic tools for any weaving.

BERGERE 24"

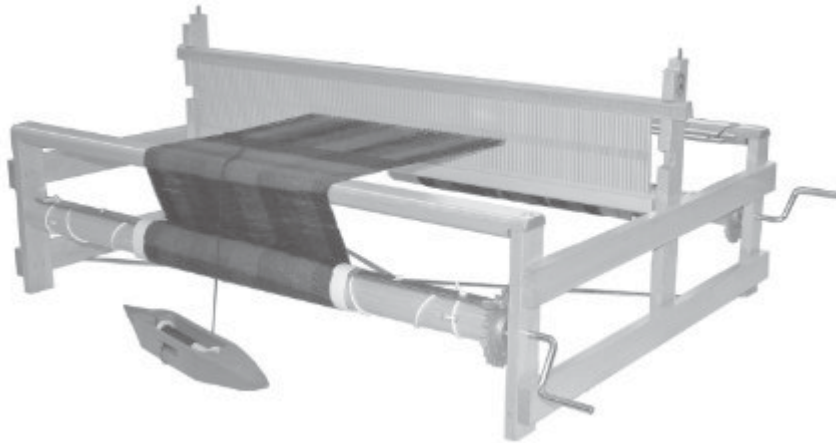

STANDARD EQUIPMENT

- » High impact styrene rigid heddle, 6 threads per inch (2.4/cm)
- » 2 flat shuttles 28" (71 cm)
- » 2 metal lease sticks
- » 2 beam sticks with cords
- » 2 warping blocks
- » Instruction and weaving book

SPECIFICATION

- » Depth: 20" (51cm)
- » Height: 11½" (30cm)
- » Width: 26¾" (68cm)
- » Weaving width: 24" (60cm)
- » Shipping weight: 10 lbs (4.54 kg.)

2530-0001 24" (60 cm) \$411.00

2530-0002 24" (60 cm) (2 rigid heddles) \$466.00

2530-0003 Uprights to install a second rigid heddle \$58.00

A small table loom for introducing hand-weaving. This loom can make beautiful material with matched colours and assorted yarns in the weft. It weaves plain weave fabrics. With a pick-up stick, it is also possible to make many different designs in your weaving. The loom can also be used to do small tapestries or wall hangings. It is equipped with a rigid heddle and 2 beams. The beams allow the warping and weaving of many yards of material, up to 24" (60cm) wide.

When the warp threads are inserted in the holes and slots of the rigid heddle the action of raising and lowering the heddle gives a good shed to throw the flat shuttle. The beating can be done with the plastic rigid heddle or with the edge of the flat shuttle.

This loom is not a toy. It is a real beginner's loom, and is ideal for youngsters who want to learn weaving. The imagination and creativity shown by youngsters in designing with various colors and textures of weft is amazing.

OPTIONS:



STYRENE (PLASTIC) RIGID HEDDLES

Part No.	Dents/inch	Width	Price
6233-9086	6	8"	\$22.00
6233-9088	10	8"	\$22.00
6233-9166	6	16"	\$25.00
6233-9168	10	16"	\$25.00
6233-9246	6	24"	\$38.00
6233-9248	10	24"	\$38.00



NEW! RIGID HEDDLES

Part No.	Dents/inch	Width	Price
6243-9208	8	24"	\$49.00
6243-9212	11	24"	\$49.00



PENELOPE II 22½" - with 2 rigid heddles



STANDARD EQUIPMENT

- » 2 High impact styrene rigid heddle, 6 threads per inch (2.4/cm)
- » 2 flat shuttles 28" (71 cm)
- » 2 metal lease sticks
- » 2 beam sticks with cords
- » 2 warping blocks
- » 6 tapestry bobbins
- » Instruction and weaving book

SPECIFICATION

- » Depth: 9½" (24cm)
- » Height: 29" (74cm)
- » Width: 29" (74cm)
- » Weaving width: 22½" (57cm)
- » Shipping weight: 24 lbs (11 kg.)

2530-0000 22½" (58 cm) \$575.00



An excellent loom for beginners and hobbyists who want to learn tapestry techniques. 22½" wide tapestry loom, solid frame with 2 beams, ratchets and dogs which allow you to put on quite a long warp. It is solidly built from Canadian maple like all Leclerc looms.

OPTIONS:

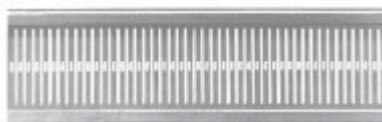

STYRENE (PLASTIC) RIGID HEDDLES

Part No.	Dents/inch	Width	Price
2420-2206	6	22½"	\$38.00
2420-2210	10	22½"	\$38.00

NEW! RIGID HEDDLES

Part No.	Dents/inch	Width	Price
2420-3206	8	22½"	\$49.00
2420-3210	11	22½"	\$49.00



GOBELIN 36", 45", 60" AND 100"



STANDARD EQUIPMENT

- » wood tapestry bobbin
- » 1 doz plastic tapestry bobbins
- » Cords
- » Book "I Weave You Weave"
- » Book " Warp & Weave"
- » Instructions

SPECIFICATION

- » Depth: 20" (51cm)
- » Height: 71" (183cm)
- » Width: 47", 56", 71" and 111"
- » Shipping weight for a 60" loom:
183 lbs (83 kg.)

A very simple loom, completely vertical. Material is stretched from one beam to the other, like the tapestry made in the "Gobelin" school in Paris.

This standard loom does not have any beater nor shaft and is used for warp tapestry weaving with string heddles or finger manipulation. The warp can obtain a very high tension by tightening two heavy screws located on each side of the loom (these screws lower the bottom beam). The rods that hold the warp are inserted in the beams.

5236-0000	36" loom	\$3696.00
5245-0000	45" loom	\$4488.00
5260-0000	60" loom	\$5280.00
5210-0000	100" loom	\$10725.00

GOBELIN LOOM WITH: 2 SHAFT FRAME

1 beater
(up and down)

This loom can be used to make tapestries or rugs.
Comes with 200 heddles and one reed (6 dents per inch).

5236-9000	36" loom	\$5636.00
5245-9000	45" loom	\$6336.00
5260-9000	60" loom	\$8448.00

KIT TO ADD ONTO A REGULAR GOBELIN LOOM:
Comes with 200 heddles and one reed (6 dents per inch).

1050-9600	for a 36" loom	\$2444.00
1050-9700	for a 45" loom	\$2731.00
1050-9800	for a 60" loom	\$3450.00

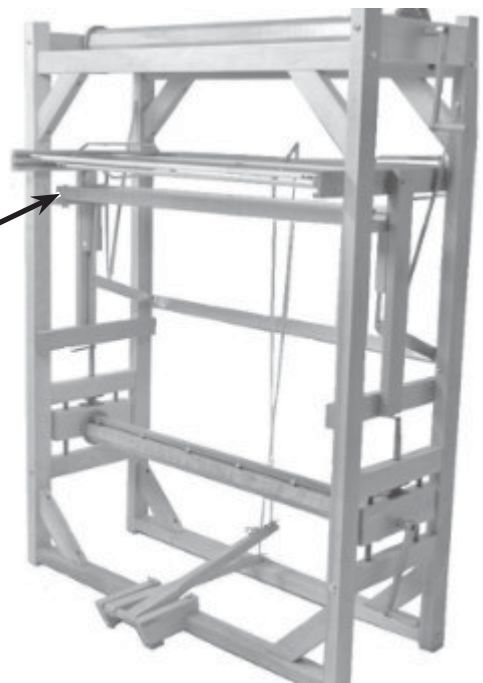

REEDS

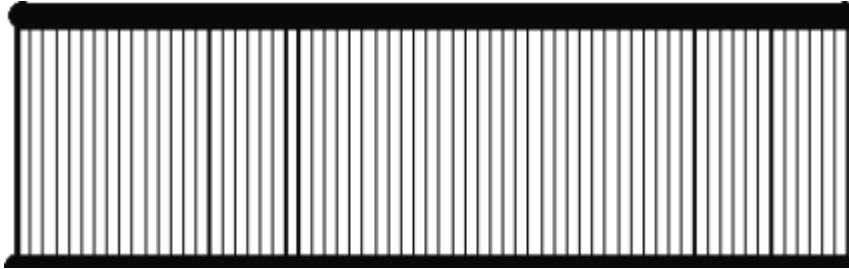

STAINLESS STEEL 3½" inside (9cm) 4¾" (12cm) outside

Availability		No:	Width:	* \$ Price: sizes	+ \$ Price: sizes
*	4 dents/inch				
	5 dents/inch				
	6 dents/inch				
	8 dents/inch				
	10 dents/inch				
	11 dents/inch				
	12 dents/inch				
	14 dents/inch				
‡	15 dents/inch	65-9-16	15¾" (40cm)	84.00	96.00
	16 dents/inch	65-9-22	22" (56cm)	117.00	133.00
	18 dents/inch	65-9-24	24" (60 cm)	128.00	145.00
	20 dents/inch	65-9-27	27" (70cm)	144.00	164.00
	25 dents/inch	65-9-32	32" (82cm)	170.00	194.00
		65-9-36	36" (90cm)	191.00	218.00
	65-9-45	45" (115cm)	240.00	273.00	
	65-9-60	60" (150cm)	319.00	363.00	
	65-9-72	72" (180cm)	383.00	436.00	
	65-9-90	90" (228cm)	478.00	544.00	
	65-9-10	100" (250cm)	532.00	605.00	
	65-9-12	120" (305cm)	639.00	726.00	

**Also available, Stainless Steel Reed
3, 4, 5, 6 and 10 dents per centimetre**

STAINLESS STEEL 4" inside (5¼" outside)

Availability: 6, 8, 10, 12 and 15 dents/inch		
No:	Width:	\$ Price: sizes
65-8-09	9½"	107.00
65-8-16	15¾"	107.00
65-8-22	22"	147.00
65-8-24	24"	164.00
65-8-27	27"	182.00
65-8-32	32"	218.00
65-8-36	36"	242.00
65-8-45	45"	303.00
65-8-60	60"	403.00
65-8-72	72"	416.00
65-8-90	90"	605.00
65-8-10	100"	678.00
65-8-12	120"	811.00



BENCHES

OPEN END BENCH (2 sizes)



All Leclerc benches are made of the finest Canadian maple. They are finished with clear lacquer and varnish to match our looms.



They are both comfortable and practical, and fit under the breast beam of the loom when not in use.

	Height	Length	\$	Bench for:
6384-2000	23" (58cm)	38" (96cm)	\$834.00	Artisat 36", Nilus, Inca, Mira and Fanny
6384-4000	26" (66cm)	44" (120cm)	\$906.00	Nilus II, Colonial, Nilart Kebec and Weavebird loom.

ADJUSTABLE HEIGHT BENCH



Bench recommended for the Compact 24", the Artisat 24", the Minerva loom and for the table looms when used on a stand.

Adjustable in height from 21" to 25" (53 to 63.5 cm).

The seat length is 24" (61 cm).

6384-6000 390.00 \$



ROCKING BENCH

Selecting the proper Loom Bench is one of the most important decisions a weaver must make. The ability to weave over long periods of time without excessive interruptions for fatigue depends heavily on the weaver's comfort.

Up until now, finding a Bench with just the right height and seating area has been difficult, but even when that is accomplished, the most common complaint by weavers is the leg numbness experienced from the seat edge cutting into the back of the legs (especially for shorter weavers).

Leclerc's new Rocking Bench has solved the dilemma.



Adjustable in 1" increments from 21" to 26³/₄" this Bench will satisfy virtually all height requirements. In addition, the seat can be lock in two different positions at any height providing an aligned surface to the back of the Leg when the Treadles are being depressed. This alignment eliminates the seat edge cutting into the back of the leg shutting off blood circulation.

As an additional feature, if the weaver prefers, the seat can be allowed to move or float with the body through the full 90 to 78 degree arc so the seat is always aligned flush with the angle of the leg.

With a full 12" by 24" seat area, this Bench will provide maximum comfort over extended weaving periods.

Bench (15 lbs) 6384-7000 \$718.00

Matching Bench Bags are an added feature. Leclerc has designed two weaver's auxiliary pouches made of durable Jean material (same as the Voyageur bag) to hold all the misc. tools a weaver needs at their finger tips. The bags attach to each side of the seat.

Bench Bags (2) 6384-7002 \$136.00



SECTIONAL WARP BEAM FOR DIRECT WARPING FROM SPOOLS OR SMALL BOBBINS

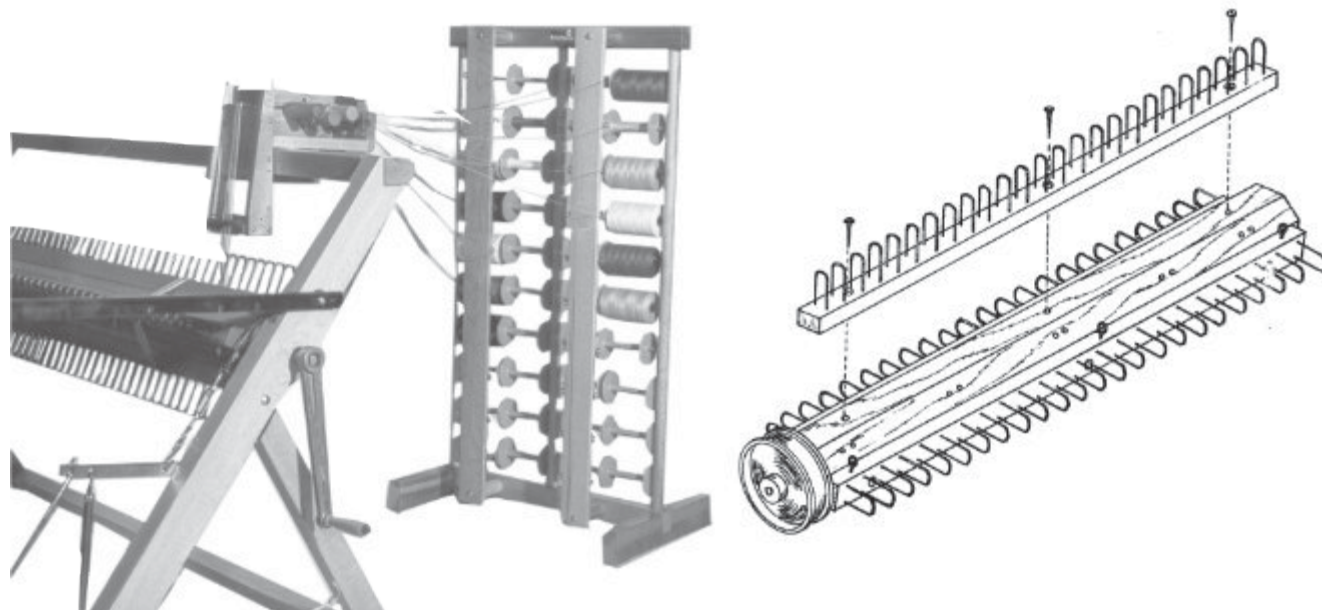

This system consists of 4 rake-like pieces that are attached to the plain beam on the loom or onto the double warp beam. It allows warp beaming 1" or 2" wide (25 mm or 50 mm) at a time and requires a number of spools according to the sett of warp ends. On the Dorothy and the voyageur, the clamps are fixed directly on the beam; it holds 5" (12,5 cm) by turn. The Compact holds 15" (38 cm) per turn while on an Artisan or Inca, it holds 16" (40 cm) per rotation. On a Fanny, Mira, Nilus, Nilus II, Colonial I, Kebec or Nilart, it holds 19" (48 cm) per rotation. A sectional warp beam is especially appreciated by the weaver without a helper since the warp can be beamed easily by one person.

1" (25mm) sections		
6443-1001	15¾"	\$516.00
6443-1100	24" Dt & Voy (23")	\$516.00
6443-2000	22"	\$357.00
6443-3000	24"	\$393.00
6441-3000	27"	\$393.00
6443-4000	32"	\$393.00
6441-4000	36"	\$393.00
6441-5000	45"	\$480.00
6441-6000	60"	\$605.00
6441-6720	72"	\$736.00
6441-7000	100"	\$874.00
6441-8000	120"	\$1196.00

2" (50mm) sections		
6442-4000	36"	\$331.00
6442-5000	45"	\$367.00
6442-6000	60"	\$482.00
6442-7000	100"	\$750.00
6442-8000	120"	\$951.00

EXTENSION KIT TO CONVERT SECTIONAL WARP BEAM TO 1 YARD PER TURN (91 CM)

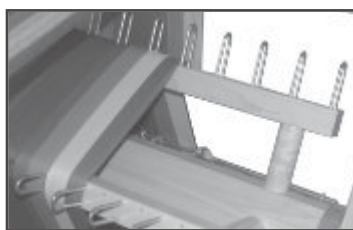

Note: not for the Compact and Artisan looms

6161-2000	For loom from 27" to 36" (70 - 90 cm) 12 pieces	\$76.00
6161-6000	For 45" (115 cm) loom 16 pieces + 12 blocks	\$165.00
6161-7000	For 60" (150 cm) loom 16 pieces + 12 blocks	\$165.00
6162-4000	For 100" (250 cm) loom 24 pieces + 40 blocks	\$200.00
6162-5000	For 120" (300 cm) loom 32 pieces + 56 blocks	\$241.00
6161-7200	For 72" 16 pieces + 20 blocks	\$269.00



SECTIONAL WARPING

TENSION BOX



New! 2024

The tension box is used with the Sectional Warp Beam and is adjustable to fit any Leclerc floor loom. The tension is adjustable for uniform tension on all warp ends as they are wound from the spool rack to the loom.

Two open 12 threads per inch (4.8 / cm) combs allow easy threading and help guide threads into the proper section.

The tension box can also be used with an optional counter when filling bobbins to give the number of meters or yards on bobbins. **6160-1000 \$255.00**

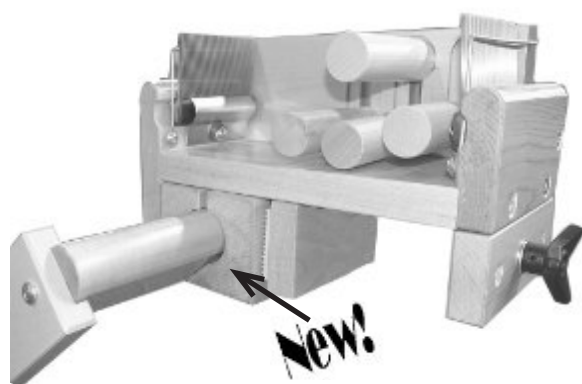

New!

Compact Loom Tension box adaptor

This part allow the tension box to be at the horizontal position when sitting in the back breastbeam of the Compact loom 24"

6160-1020 \$165.00

COUNTER

The counter is placed on the tension box and measures the yardage of the warp to ensure that all sections are of the same length. Easily removable from the tension box.

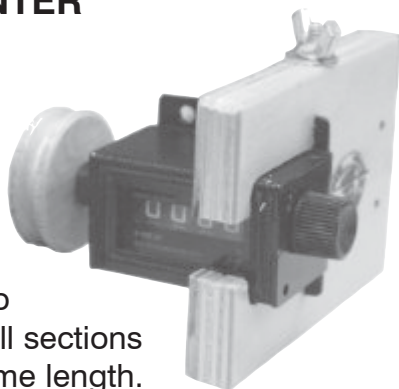

6160-6000 (english system) \$167.00
6160-8000 (metric system) \$167.00

TENSION BOX EXTENSION

This extension with one comb close to your warp gives you better control on the width of the yarn section (1" or 2") so the guides are not needed. Height of comb is adjustable. Good for sectional warp beam with or without extension.

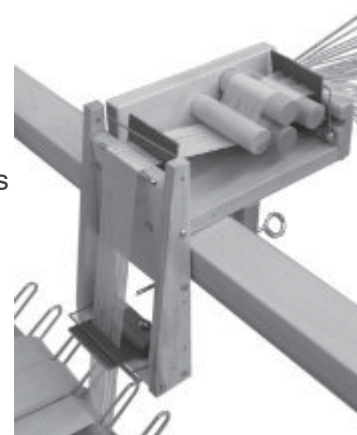

1042-0000 \$105.00



SECTIONAL WARPING

DIVIDERS



Useful when beaming long warps. They are placed in each section every 5 or 10 yards (meters) to prevent uneven build-up of threads and keep uniform tension in the warp. They all have to be placed in the same turn

6165-1000 1" (25mm) sections \$31.00 / 100

6165-2000 2" (50mm) sections \$42.00 / 100

GUIDES

A set of 8 pieces that fit the steel divisions for each section of the sectional warp beam. They prevent the warp ends from going into other sections, or from staying on top of the divisions. When the section is filled, transfer to the next section.

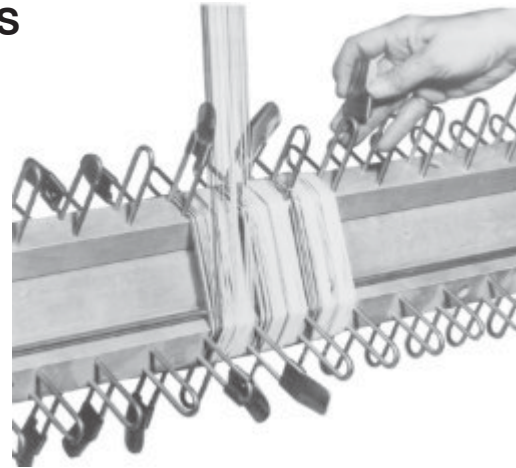

6166-1000 \$24.00 per set of 8

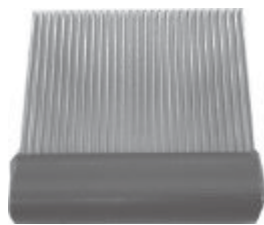

COMB FOR TENSION BOX

Any reed size available.
Indicate number of dents per inch (cm).

6260-0000 \$11.00

DOUBLING STAND

Doubling stand used for twisting two or three threads together.

One tube of yarn is placed on the floor, one on the lower shelf and one on the center shelf.

Thread passes through the center of the middle and upper cones (or tubes).

Thread from upper shelf then joins the two lower ones and passes through the hole in the top shelf.

Hang on wall (2 screws included) 2½" x 5½" x 25"
(Made of maple)



6360-1000 \$95.00



BOBBIN RACKS

BOBBINS OR CONE HOLDER

With 8 pegs and 8 pigtail eyes screws as guides. Use with warping boards or vertical warping mills.

6361-1000 \$215.00



BOBBIN RACK

This bobbin rack can hold fifty 4" - diameter bobbins (or tubes) or thirty 8" - diameter cones. Each thread is guided by a pig tail eye which makes the threading easier. There is an additional row of pig tail eyes so that all bobbins of all sections can be either unwound at the end or unrolled. The bobbin rack can be folded for storage. During warping, it must be open to an angle which will give the rack stability and uniform tension on the threads.

6362-9900 \$774.00

Dimension closed = 57.5" x 28" (wide) x 6"
Dimension open at 180° = 57.5" x 55" (wide) x 6"

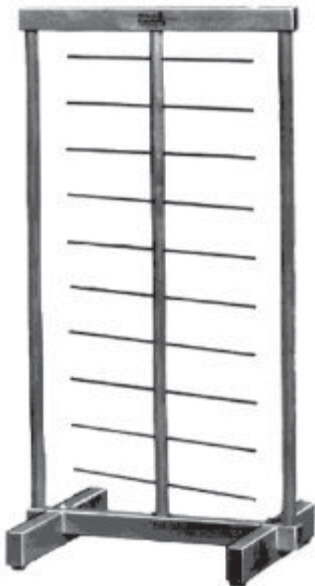

BOBBIN STAND

Can hold forty 4" (102 mm) spools. Built like a frame: 21" x 37" (53 cm x 94 cm) with two removable supports. The pins are fixed to a central post that can be turned out when removing bobbins.

6362-1000 \$266.00



THREAD GUIDE

Needed when warping with yarn on tubes, this thread guide prevents the yarn from slipping off the end of the bobbin by always pulling from the center. It has 2 thread guides, each having 40 thread eyes. **6362-2000 \$165.00**

BOBBIN RACK WITH THREAD GUIDE INSTALLED: 6362-3000 \$392.00



- Thread Guide with pigtail screw instead of eyescrew **6362-2001 \$254.00**
- Bobbin Rack with thread guide install with pigtail screw **6362-3001 \$502.00**
- Pigtail screw **6362-3002 \$3.45 each**



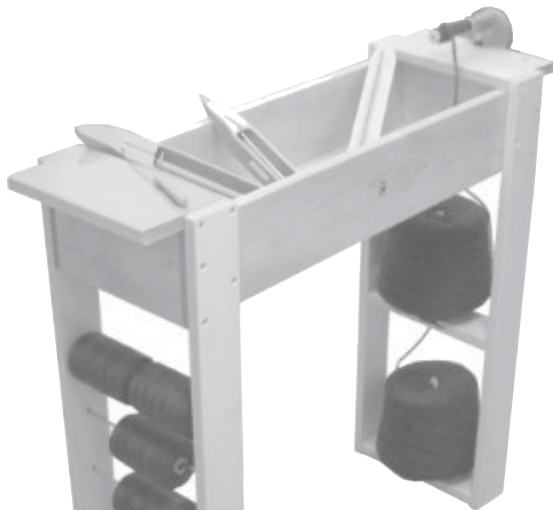

"HOLDS-ALL"

TO BE CONVENIENTLY PLACED NEAR THE LOOM

Here is a way to keep tools neatly arranged while you weave. This Holds-All can hold a multiple of accessories and fibers.

It is also designed to allow you to fasten a hand bobbin winder onto it, or use it as a doubling stand. And, it includes a spool rack that holds up to 10 spools or bobbins.

To double 2 threads together with a little twist: Place one cone or one tube on each shelf. Pass the bottom thread through the metal tube. Join the two threads and pass them through the holes at the bottom of the Holds-All.

More cones can be put on the floor to ply more threads.

Made out of Maple with the Leclerc finish.

Dimensions: Width: 34½", Height: 31", Depth: 11½",
Weight: 20 lbs

6370-1000 \$594.00



REED STAND

With this accessory, all your reeds can be stored in order as well as the raddles, lease sticks and the metal rods.

Width: 27¼",
Depth: 14½",
Height: 24¾"

6380-1000 \$409.00

BOBBIN WINDERS

HAND BOBBIN WINDER

A light but strong hand bobbin winder with completely covered gear. Tapered plated shaft for all Leclerc bobbins and Leclerc Spools. Clamps to a table top up to 1½" thick. Set on special permanent greased bushing. Turning ratio: 1/7.5
Wood handle

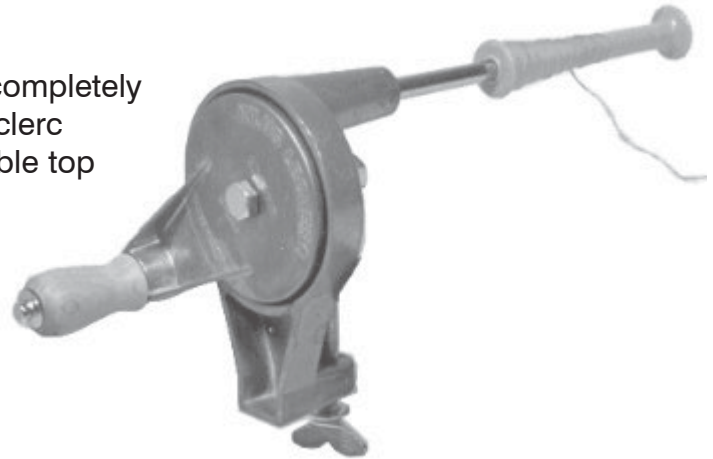

6331-1000 \$164.00

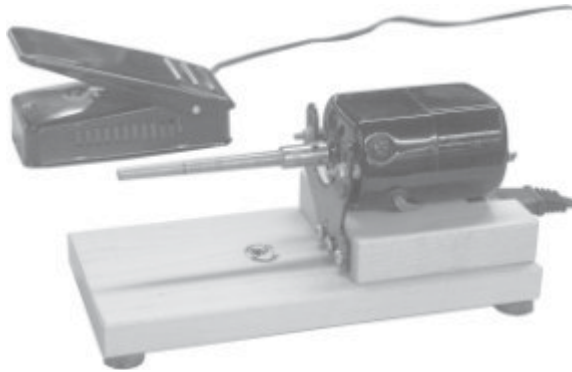

ELECTRIC BOBBIN WINDER

With a tapered shaft to be used on regular Leclerc 4" (10 cm) bobbins, 6" (15 cm) bobbins, and Leclerc spools.
Foot operated speed control.

6334-1000 \$285.00

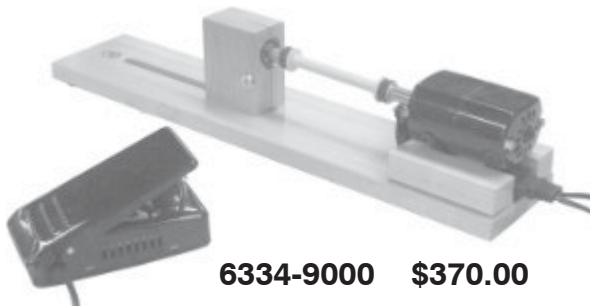

6334-9000 \$370.00

ELECTRIC BOBBIN WINDER

Holds both ends of bobbins, spools or pirns. Designed for bobbins, spools or pirns of any length between 2.75" to 8" (25 mm to 20 cm).
Foot operated speed control

With the tension device and the counter (Yard or Meter)

**6334-9001
\$599.00**

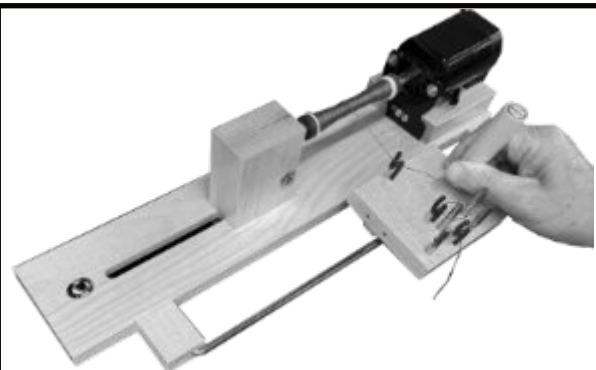
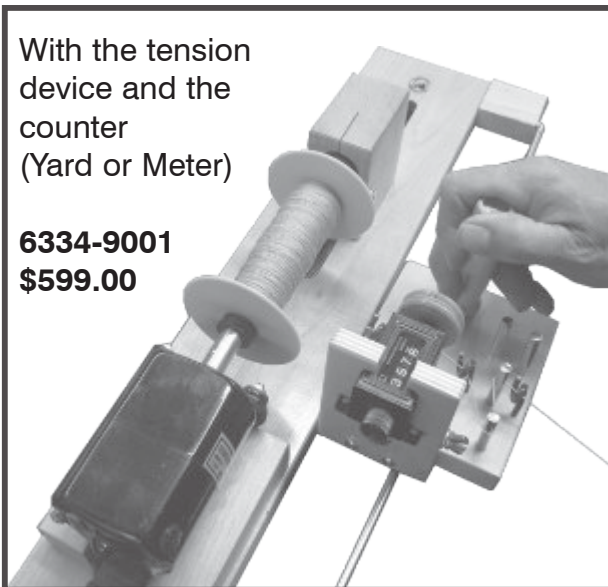

With the tension device
6334-9002 \$515.00

Tension device alone for existing winder
6334-9003 \$212.00

FRINGE TWISTER

developed by Russ & Melody Lang

To twist fringe, decide on the number of strands to be included, and divide them into groups. Clamp one group into each clip, and holding the wooden crank in the center, crank clockwise as many times as desired or until the strands start to kink. Holding the ends of each group, remove them from the clips. Allow the bundles to entwine. Tie

Double 5682-5683 \$22.00 ends together with
Triple 5683-5683 \$25.00 an overhand knot.
Quad 5684-5683 \$32.00

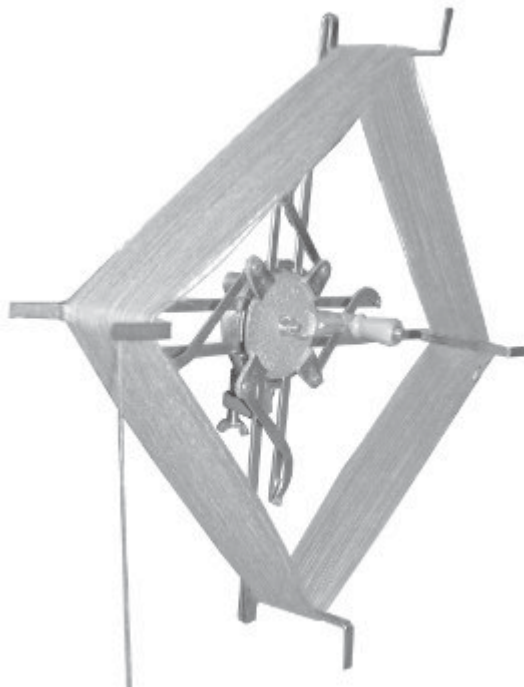
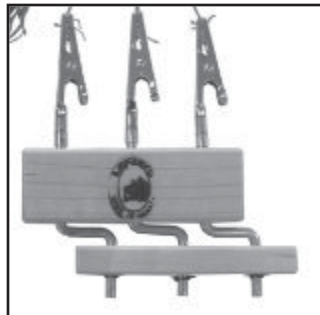
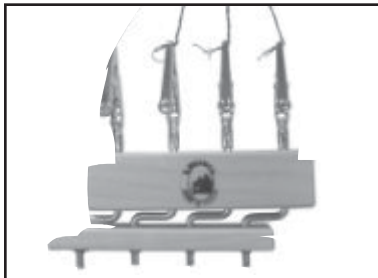
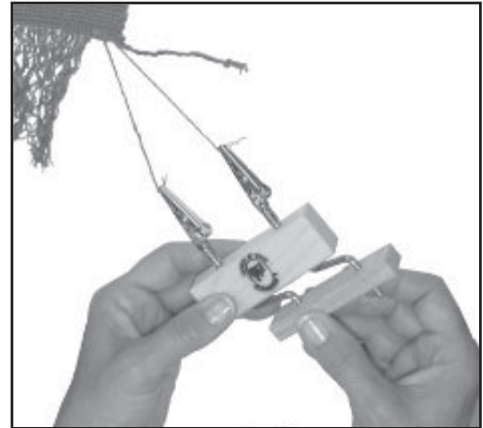

SKEIN WINDER

Reel or swift (made of metal) which may be clamped to table top. Adjustable for different sizes of skeins, from 40" to 60" (102 cm to 150 cm) Clamps to a table top up to 1½" thick.

6351-4000 \$392.00

UMBRELLA SWIFT

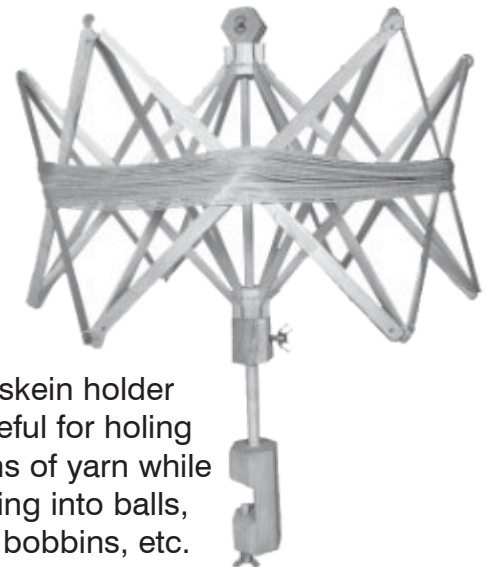

This skein holder is useful for holding skeins of yarn while winding into balls, onto bobbins, etc. Spins around smoothly. All wood construction. For table attachment. Circumference: adjustable up to 75" (188 cm)
 Dimensions when collapsed:
 9¼" x 23" (25 x 58 cm)

6350-2000 \$128.00

BOBBINS AND FLAT SHUTTLES

STYRENE (plastic) BOBBINS FOR BOAT SHUTTLE

6133-6000 4" (10 cm) \$17.25 / 12 bobbins

6133-8000 6" (15 cm) \$24.00 / 12 bobbins



STYRENE (plastic) SPOOLS 4" (10 cm) LONG

Can hold ½ lb. (227 g) of yarn

6133-1000 \$5.75 each

FLAT SHUTTLE:

Used with simple looms or when only a few rows of thread are required. The knife shape edge can be used to beat the weft.



6112-1000	6"	\$9.00
6112-2000	10"	\$11.50
6112-3000	14"	\$12.65
6112-4000	18"	\$13.80

6112-5000	21"	\$15.00
6112-8000	28"	\$20.00
6112-9000	36"	\$23.00

Flexible plastic Netting Needles - Plastic flat Shuttle

Ideal for pick-up, inlay and netting. Made of a strong nylon.



6110-5000 Small	5¼" x 5/8" (13 cm x 15 cm)	\$5.75
6110-6000 Medium	6½" x 7/8" (17 cm x 22 cm)	\$5.75

6110-8000 Large	8" x 1" (20 cm x 25 cm)	\$6.90
6110-9000 Ex. large	10 3/8" x 1¼" (26 cm x 30 cm)	\$8.00



BOAT SHUTTLES

- | | |
|----------------------------|------------------------------|
| » MADE FROM CANADIAN MAPLE | » BOBBIN SUPPORT WITH SPRING |
| » WELL BALANCED & SMOOTH | » 5 SIZES TO CHOOSE FROM |
| » CLOSED BOTTOM | » BEAUTIFULLY SHAPED |

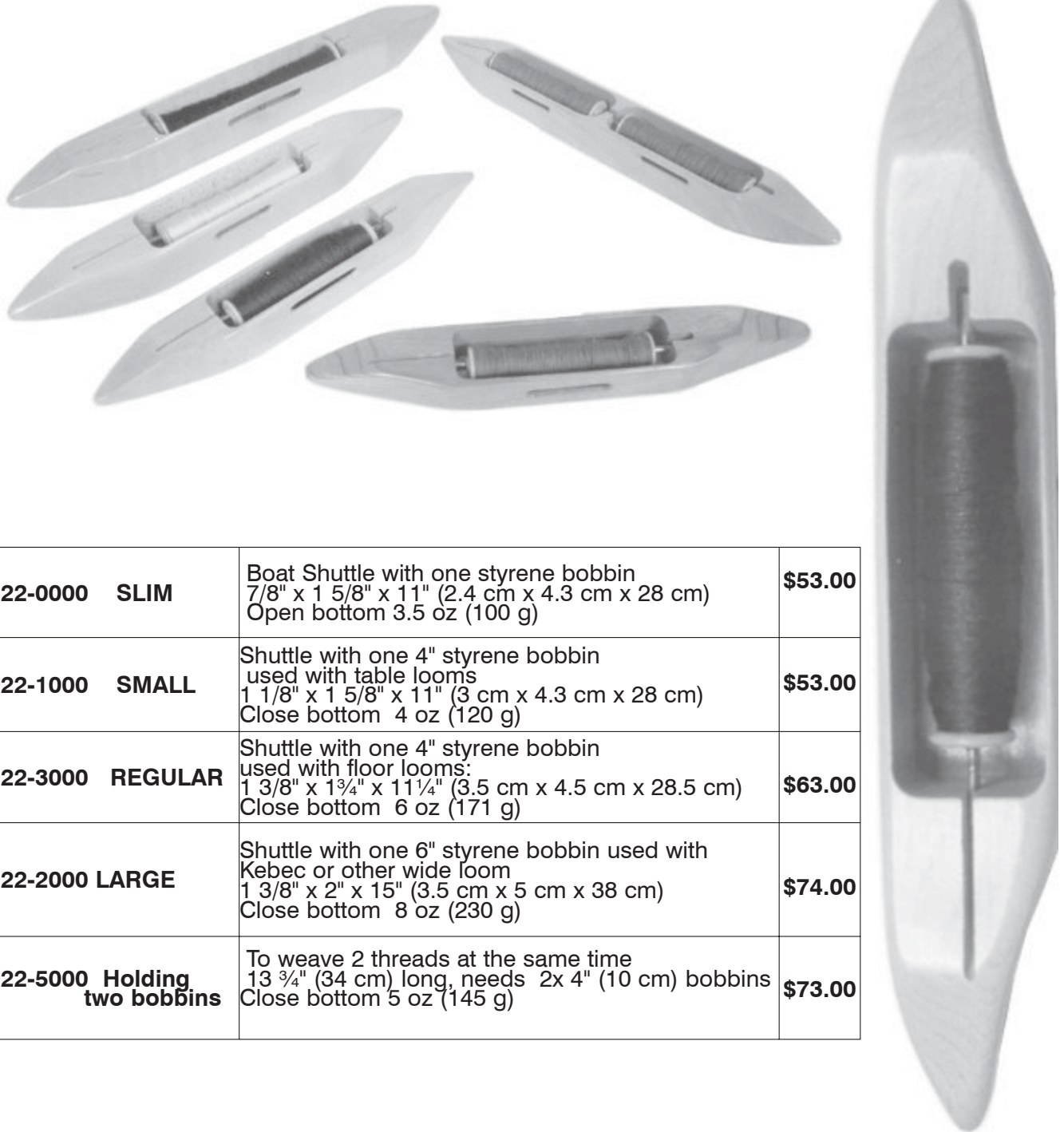

6122-0000	SLIM	Boat Shuttle with one styrene bobbin 7/8" x 1 5/8" x 11" (2.4 cm x 4.3 cm x 28 cm) Open bottom 3.5 oz (100 g)	\$53.00
6122-1000	SMALL	Shuttle with one 4" styrene bobbin used with table looms 1 1/8" x 1 5/8" x 11" (3 cm x 4.3 cm x 28 cm) Close bottom 4 oz (120 g)	\$53.00
6122-3000	REGULAR	Shuttle with one 4" styrene bobbin used with floor looms: 1 3/8" x 1 3/4" x 11 1/4" (3.5 cm x 4.5 cm x 28.5 cm) Close bottom 6 oz (171 g)	\$63.00
6122-2000	LARGE	Shuttle with one 6" styrene bobbin used with Kebec or other wide loom 1 3/8" x 2" x 15" (3.5 cm x 5 cm x 38 cm) Close bottom 8 oz (230 g)	\$74.00
6122-5000	Holding two bobbins	To weave 2 threads at the same time 13 3/4" (34 cm) long, needs 2x 4" (10 cm) bobbins Close bottom 5 oz (145 g)	\$73.00



"TRADITIONAL" BOAT SHUTTLE



To commemorate the 125th Anniversary of Leclerc Looms, we have re-introduced the traditional Shuttle which is reminiscent of those produced by the company during its first century of operation. Designed to match the beautiful

hand-crafted shuttles made in years gone by, the graceful shape of the Traditional shuttle fits perfectly into the natural curves of the weaver's hand.

Each shuttle is crafted from kiln dried Canadian maple to give you years of weaving enjoyment.

1 1/8" X 1 5/8" X 11 1/4" 4 oz.(113g) **6122-6000 \$63.00**

LECLERC END-FEED SHUTTLE



The hand end feed shuttles are: 13" long x 1 3/4" deep x 1 3/8" high. 6.8 oz.(194 g)

A special tension device allows the weaver to adjust the tension for each type of yarn giving a perfect selvage while increasing weaving speed. Yarn feeds through the tension device quickly and easily. The shuttle come with one new professional wood pirn 6 1/4" long. **6124-8000 \$205.00**

Professional pirns 6 1/4" long:
6124-6000 \$52.00/12



SHUTTLE FOR FLYING SHUTTLE BEATER

Professional Shuttles for Flying Shuttle beaters are: 15" long x 1 5/8" deep x 1 3/8" high. They weigh 1lb (453g) including the pirn. A special tension device allows the weaver to

adjust the tension for each type of yarn giving a perfect selvage. Yarn feeds through the tension device quickly and easily.

Our professional pirns are 7" long.



6124-9000 \$350.00



Professional pirns 7" long:
6124-7000 \$55.00/12





Colored Shuttle with one 4" styrene bobbin appropriate for use with all Loom models. Ideal for beginners and experienced weavers alike, this is a unique cost effective Shuttle that will perform. Made of high impact plastic (High Density Polyethylene) this shuttle will last a lifetime. The

shape and weight are comparable to the Leclerc Traditional Shuttle. Available in 4 colors The shuttle measures 1 1/8" X 1 5/8" X 11 1/4" and Weighs 4.7 ounces.

6122-7000 (RED) \$27.50 each

6122-7001 (BLUE) \$27.50 each

6122-7002 (YELLOW) \$27.50 each

6122-7003 (GREEN) \$27.50 each



SKI SHUTTLES: made for medium to heavy yarn or rags, this special shuttle has the yarn wrapped horizontally around it so it slides easily in the warp. We produce two different sizes of ski shuttles.

6121-6000 1 3/8" x 1 1/2" x 17 3/4" (3,5 cm x 3,8 cm x 45 cm)

Net weight: 5 oz (142 g) **\$56.00 each**

6121-7000 1 3/8" x 2" x 27 1/2" (3,5 cm x 5 cm x 69 cm)

Net weight: 9 oz (256 g) **\$72.00**



REGULAR RAG SHUTTLE: made of maple, smooth varnish finish

1 1/2" x 2 1/2" x 15" (3,8 cm x 6,4 cm x 38 cm)

Net Weight: 4 1/2 oz (128 g) **6120-7000 \$53.00**



RAG SHUTTLE WITH REMOVABLE ROD to hold one or many bobbins. There is a hole in the edge for the thread.

6120-9000 1 1/2" x 2 1/2" x 15" (3,8 cm x 6,4 cm x 38 cm)

Net weight: 5 1/2 oz (157 g) **\$55.00**

6120-8000 1 1/2" x 2 1/2" x 22" (3,8 cm x 6,4 cm x 56 cm)

Net weight: 8 oz (228 g) **\$60.00**

VERTICAL WARPING MILL OR REEL

Reels are the fastest way of making chained warps with a variation of threads and colors. The cross sections that hold the pegs may be adjusted up or down, depending on the warp length. When the mill is not in use, the cross sections and pegs can be removed so that the mill folds to occupy a very limited space.



THE TABLE MODEL gives 2 yards (1.8 meters) per rotation and can warp up to 22 yards Long.

Height: 38" 96 cm
Width: 26 1/4" 67 cm

6340-2000
\$538.00



THE FLOOR MODEL gives 4 yards (3.7 meters) per rotation and can warp up to 50 yards.

Height: 68" 173 cm
Width: 59" 150 cm

6340-4000
\$1234.00

These warping boards are sturdily constructed, and are easily knocked down for storage. They can be used flat on a table, or hung on a wall.

WARPING BOARDS 3 DIFFERENT SIZES

6345-0000 For warps up to 6.5 yds long 22 3/4" x 20" **\$197.00**

6345-1000 For warps up to 13 yds 22 3/4" X 41" **\$228.00**

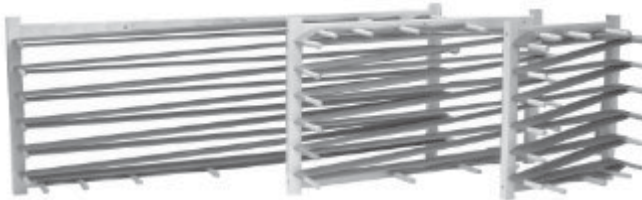

6345-5000
For warps up to 21 yards long
22 3/4" X 64" **\$323.00**

WARPING PEG: for warping small warps, clamp to top of table.

6346-1319 \$40.00 (pair)

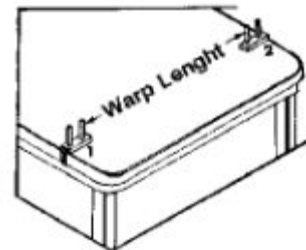

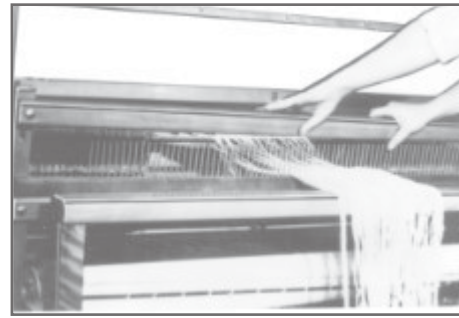

RADDLE

Fits in the beater (2 dents per inch)
Used to spread the warp when beaming. It has an open top which can be covered with top of beater.

6258-1000	Voyageur, Dorothy 15.75" (40 cm)	\$40.00
6258-2000	Meco 22" (56 cm)	\$65.00
6258-9001	Compact 24"	\$65.00
6258-9024	Voyageur, Dorothy 24" (60 cm)	\$65.00
6258-4000	36"	\$76.00
6258-5000	45"	\$95.00
6258-6000	60"	\$113.00

PADDLE

Used for warping with more than four ends (up to twenty threads). You make the cross by sliding the yarn up or down in the slot.



6148-1000 34.00

5" Thread Clipper

Lightweight and very sharp!
Right or left handed!

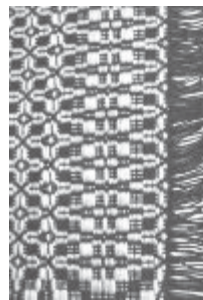

Can be used on the loom or for finishing woven fabric.

**6148-1001
\$23.00**

DROP SPINDLE

A beautifully balanced spindle, in naturally finished hard wood.

Whorl : 3½" dia. (9,5 cm)

Shaft: 14" long (35,5 cm)

6170-2000 \$55.00

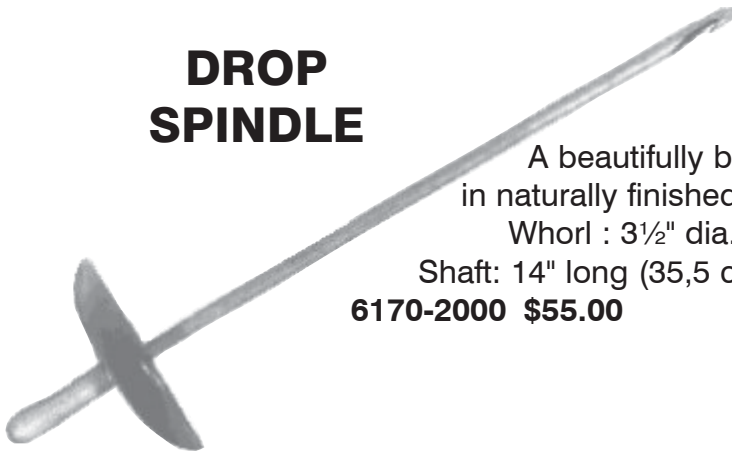



Used on counter-balanced and countermarch looms to keep shafts at same level and distance while threading.

6147-3000

\$40.00

TREADING HELPER

Used as a harness stabilizer and a support for the lease sticks and raddle. It holds the cross at a convenient height during the threading. May be used in a variety of configurations as shown below.

6147-4000 \$108.00 (2 pieces)

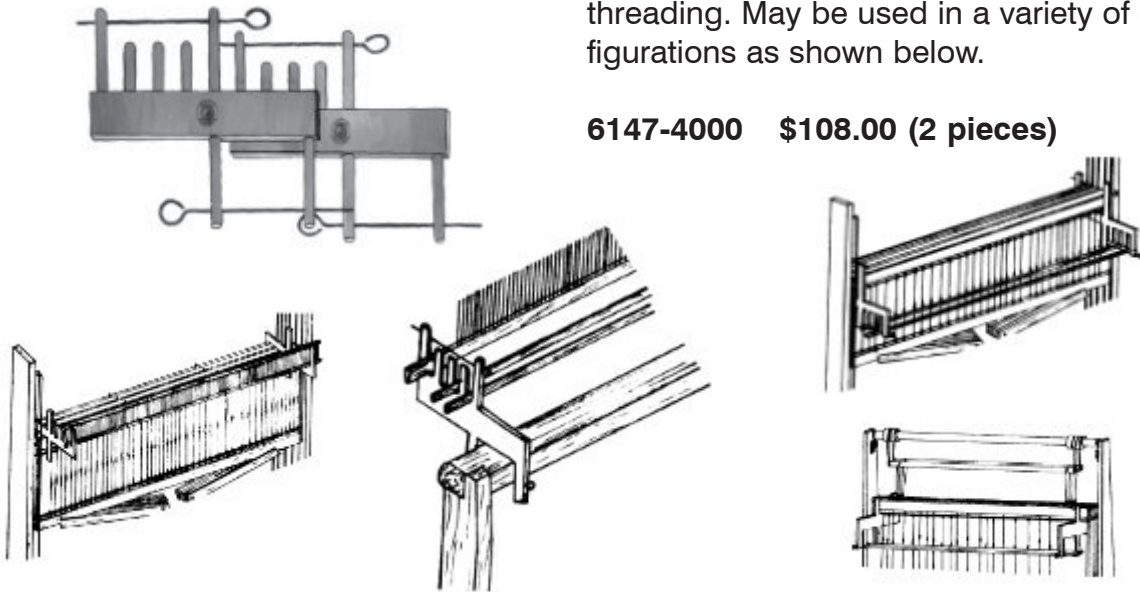

HEDDLES

Leclerc always believes that light wood frame, heddle supports and metal heddles make the best combination for the shaft frame:

- convenient to put heddles on shaft
- very easy to move heddles on heddle support
- easy threading
- easy to install repair heddles



Standard wire heddles: supplied as standard equipment for each loom



Inserted eye heddles: wire heddles with special oval shaped eye. Heddles do not catch on each other. They slide easily on heddle support. Warp threads ride through eye smoothly.



Repair heddles: ends of heddles are not soldered and can be added anywhere in harness frame



LARGE INSERTED EYE HEDDLES: the inside dimension of the eye is 1/4" x 3/8" (10 mm x 7 mm)



LONG EYE HEDDLES: the inside dimension of the eye is 2" x 3/32" (50 mm x 3 mm)



FLAT METAL REPAIR HEDDLE: the ends are made in such a way that they can be added anywhere, anytime.



Texsolv System heddles are made in joined 100-heddle bundles. The strong, durable polyester is crocheted without knots. Heddles do not stretch. On all Leclerc Looms, heddles slide easily on heddle supports. Eye Lengths: 1/2"

Overall:	WIRE HEDDLES	INSERT EYE	WIRE REPAIR	LARGE EYE	LONG EYE	FLAT REPAIR	TEXSOLV
9 1/2" (240 mm)	6291-2000 \$15.50/100	6292-2000 \$27.50/100	6294-1000 \$5.50/12			6294-2000 \$5.50/each	6298-0900 \$24.00/100
9 1/2" (240 mm)	0629-1200 \$70.00/500	0629-2200 \$119.00/500					
10-5/8" (270 mm)	6291-4000 \$16.50/100	6292-4000 \$28.50/100	6294-3000 \$5.50/12	6295-4000 \$84.00/100		6294-6000 \$5.50/each	6298-1000 \$24.00/100
10-5/8" (270 mm)	0629-1400 \$76.00/500	0629-2400 \$122.00/500					
12-5/8" (320 mm)	6291-6000 \$19.00/100	6292-6000 \$28.50/100	6294-5000 \$5.50/12	6295-6000 \$91.00/100	6296-6000 \$50.00/100	6294-7000 \$5.50/each	6298-1200 24.00/100
12-5/8" (320 mm)	0629-1600 \$84.00/500	0629-2600 \$133.00/500					
14" (356 mm)		0629-2800 \$147.00/500	6294-8000 5.50/12			6294-8001 5.50/chaque	6298-1400 24.00/100

SHAFT FRAME

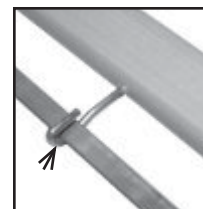
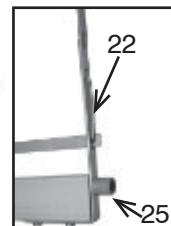
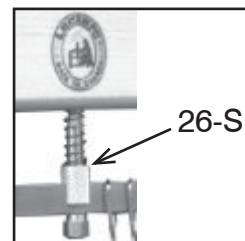
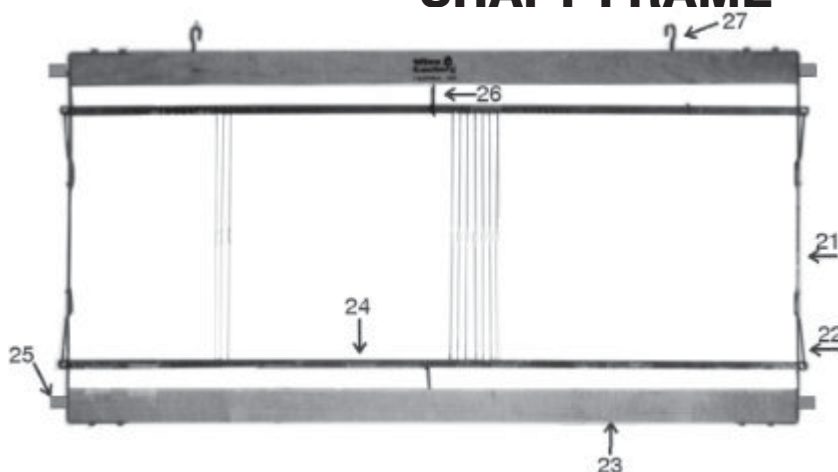

Shaft frames for Dorothy 15 $\frac{3}{4}$ " and 24" looms are all metal.
 Shaft frames for Compact 24" looms have a maple frame with metal heddle support.
 Shaft frames for all other looms are made of light wood and metal.

HARNESS FRAME WITH HEDDLE SUPPORTS BUT WITHOUT ANY HEDDLES					HEDDLE SUPPORT (#24 each)	WOOD FRAME (#23 each)
		36"	45"	60"		
Dorothy 15 $\frac{3}{4}$ "	2110-4139 \$37.00				\$8.00	
Dorothy 24"	2110-4140 \$46.00				\$9.00	
Compact 24"	1022-2200 \$92.00				\$10.00	
Mira, Fanny 27"	4030-0001 \$115.00				\$12.00	\$33.00
Artisat 36"	3040-0012 \$127.00				\$14.00	\$44.00
Mira, Fanny		4040-0012 \$127.00	4050-0012 \$174.00	4060-0012 \$225.00	all 45" \$18.00	all 45" \$44.00
Nilus		3150-0012 \$127.00	3150-0013 \$174.00	3160-0013 \$225.00	all 60" \$23.00	all 60" \$62.00
Nilus II		1026-4200 \$127.00	1027-4200 \$174.00	1028-4200 \$225.00		
Colonial			3550-0012 \$174.00	3560-0012 \$225.00		
Nilart			3250-0011 \$174.00	3260-0011 \$225.00		
Kebec 100"	4370-0011 \$305.00				\$40.00	\$126.00
Kebec 120"	4380-0011 \$341.00				\$44.00	\$136.00

SHAFT FRAME PARTS

(#21) Shaft frame ends with heddle support spring	(each)	10 $\frac{1}{2}$ "	4210-1000	\$23.00
		12 $\frac{1}{2}$ "	4210-1200	\$25.00
(#22) Spring Clip only for shaft frame end (each):	4249-0000	\$	3.50 each / \$50.00 set of 16	
(#26-S) Spring hook for heddle support:			5500-0000	\$16.00
(#26) Flat Hook for heddle support:			4230-0000	\$ 2.50
(#27) Hook for shaft frame:			4270-0000	\$ 2.50
(#25) Shaft frame end (beige plastic)			6102-0000	\$ 2.50
(#25) Shaft frame end (beige plastic) (set of 16)			6102-0001	\$33.00
Crochet en V pour le bas du bois de cadre (Mira, Fanny)			4280-0000	\$23.00
Shaft Frame Divider (peg)			0342-6102	\$ 1.50
Shaft Frame Dividers (peg) set of 20			0342-6103	\$27.00

6141-6000	Styrene reed hooks (for any size of yarn) (5-3/8" overall)	\$2.35
6141-7000	5" (13 cm) long, with a styrene handle. For 4 shaft looms (8¾" overall)	\$6.60
6140-8000	5½" (14 cm) long with a wooden handle. For 4 shaft looms (8¾" overall)	\$9.90
6140-9000	8 5/8" (22 cm) long, with a wooden handle. For 8 shaft looms. (12" overall)	\$11.00
6140-1000	10 5/8" (27 cm) long, with a wooden handle. For 12 shaft looms (13¾" overall)	\$11.50

HOOKS



TEMPLES

A device to maintain the warp width as sleyed in the reed and prevent narrowing. We have 5 different sizes to choose from.

NO.	FROM	TO	PRICE
6146-1000	11" 28 cm	16" 40 cm	\$61.00
6146-2000	16" 40 cm	22" 56 cm	\$67.00
6146-3000	23" 58 cm	38" 96 cm	\$75.00
6146-5000	36" 90 cm	60" 152 cm	\$95.00
6146-6000	56" 142 cm	100" 250 cm	\$135.00
6146-8000	76" 190 cm	120" 300 cm	\$162.00

CLIP TEMPLE

6146-0000 \$115.00



ACCESSORIES FOR TAPESTRY

PICK-UP STICKS



A small pick-up stick with a sharp point and a needle eye to carry the weft if necessary. 8 3/8" (212 mm) long.

6154-4000 \$11.00

Small for pattern weaving. 10" (25 cm) long

6154-2000 \$11.00

Medium 14 1/8" (36 cm) long

6154-3000 \$11.00

A pick-up stick with bevelled ends.

18 1/2" (47 cm) x 1/2" (12mm) x 1/8" (2mm) thick

6154-5000 \$13.00

TAPESTRY BOBBINS



Small tapestry bobbin in high impact styrene (plastic) 5" (127 mm) long, 7/16" (11 mm) diameter

6150-5000 \$20.00 / 12

LIGHT COMB



A light comb with teflon coated teeth to beat a tapestry weave. 8" (20 cm) long 2 1/4" (55 mm) wide 8 teeth : 1 3/4" (45 mm) Weight: 1/4 pound (115 g)

6153-1000 \$69.00

HEAVY COMB

A heavy, lead weighted comb in natural finish hard maple, to beat weft for carpets of knotted pile or any material you want to be very stiff.

Width: 2 13/16" (72 mm) 13 dents

Weight: 2 pounds (900 g) **6153-5000 \$176.00**

ACCESSORIES

WOODEN WARP STICKS

Useful when beaming a long warp. They maintain perfect tension, and prevent edge threads from slipping down. Use 2 per turn. Sold by the dozen only. Width: 3/4" (19 mm)

6240-1000	15 ³ / ₄ " (40 cm)	33.00 (12)
6240-2000	DT-VOY 23 ¹ / ₂ "	34.00 (12)
6241-2000	CP 25 ¹ / ₂ "	34.00 (12)
6240-3000	27" (70 cm)	35.00 (12)

6240-4000	36" (90 cm)	40.00 (12)
6240-5000	45" (115 cm)	44.00 (12)
6240-6000	60" (155 cm)	46.00 (12)

CRANK FOR LOOMS



For Bergere, Penelope, Dorothy and Voyageur 3000-5801 **\$34.00**

For Compact and Artisat Loom 3000-5892 **\$101.00**

For Mira, Fanny, Nilus, Nilus II, Kebec, Colonial, Nilart and Weavebird looms 3000-5862 **\$124.00**



Set of 6 treadle hooks (7") for 4 shaft loom	3000-4521	\$16.50
Set of 10 hooks (10") for 8 shaft loom	3500-4521	\$24.00
Set of 10 hooks (12") for 8 shaft loom	3201-4521	\$25.00
Set of 14 hooks (13.5") for Nilart 12	3202-4521	\$32.00
Set of 12 treadle CORDS (7") for Artisat, Mira, Fanny, Nilus, Colonial, Kebec, Nilart and Nilus II Back Hinge	3000-7011	\$14.00
Set of 12 treadle CORDS (9") Nilus II, Kebec II, Minerva	3400-7011	\$14.00
Set of 12 treadle CORDS (9") Compact 24"	3400-7012	\$14.00
Set of 12 treadle CORDS (6") for back hinge Nilus	3100-7011	\$14.00
Set of 12 treadle CORDS (6 ¹ / ₂ ") for back hinge Artisat	3100-7012	\$14.00
Set of 12 treadle CORDS (8 ¹ / ₂ ") for back hinge Nilus II & Colonial	3200-7051	\$14.00

CORDS

4000-7113 Set of 2 cords for upper roller; Mira, Fanny	\$11.00
6190-3001 Set of 2 cords (old, 24") MR-FN	\$11.00
3000-7123 Set of 4 cords for lower roller; Mira, Fanny	\$13.00
9300-0000 Set of 2 cords Very Old Mira (adjustable)	\$16.00
1035-0000 Set of 6 LOOP cords for upper rollers Inca, Fanny, Mira, Nilus II Colonial	\$12.00
6191-3000 Small LOOP cord per meter (1.10 yards)	\$ 2.30
6191-2000 Large LOOP cord per meter (1.10 yards)	\$ 2.30
6191-2211 Loop Cord Anchor Peg	\$ 0.55
6191-2212 Loop Cord Straight Peg	\$ 0.45
4300-7659 Solid Nylon Braided 1/8" x 5 yards (4.5 m)	\$ 5.50
4300-7679 Solid Nylon Braided 1/8" x 16 yards (14 m)	\$13.00
3000-7519 Brake cord for Mira, Fanny, Nilus and Artisat, between brake treadle and brake itself	\$ 7.50

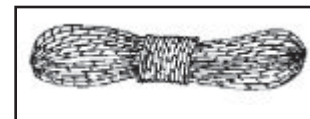
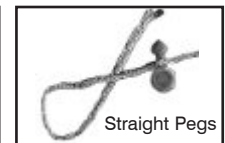
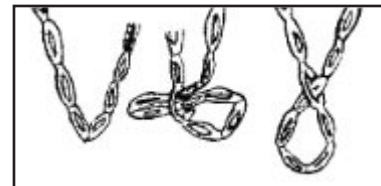

ACCESSORIES

WOOL CARDERS "Light and Strong"



6171-3000 For normal carding
wire gauge #20 (64 dts/inch)
6¾" x 10" (leather size: 6½" x 4¾")
\$91.00 (pair)

6171-4000 For finer carding or to brush
woolen blankets, tapestry, rugs, etc. wire
gauge #26 (105 dts/inch) 8½" x 10"
(leather size: 8¼" x 4¾") **\$91.00 (pair)**

WARP DRESSING



Fiber Conditioner
Specially prepared for
wool when threads stick
together or are subject to
break through lack of
dampness. Can also be
used with linen, cotton,
silk and synthetic fibers
6147-6000 \$14.00

CANVAS APRONS

6193-1000	15¾" (40 cm)	\$34.00 each
6193-2000	22" (56 cm)	\$38.00 each
6193-3000	24" (60 cm)	\$42.00 each
6193-4000	27" (70 cm)	\$48.00 each
6193-5000	32" (80 cm)	\$53.00 each
6193-6000	36" (90 cm)	\$53.00 each
6193-7000	45" (115 cm)	\$67.00 each
6193-8000	60" (150 cm)	\$86.00 each
6193-9000	90" (175 cm)	\$99.00 each
6193-9100	100" (250 cm)	\$124.00 each
6193-9200	120" (300 cm)	\$153.00 each

LEASE STICKS (each)

		METAL	WOOD
2010-3919	15¾" (40 cm)	\$7.70	
2010-3929	15¾"		\$12.50
2020-3919	22" (56 cm)	\$10.00	
2020-3929	22"		\$12.50
1022-3919	24" (60 cm)	\$10.00	
1022-3929	24"		\$19.00
3030-3919	27" (70 cm)		\$22.00
3040-3919	36" (90 cm)		\$22.00
3050-3919	45" (115 cm)		\$24.00
3060-3919	60" (150 cm)		\$34.00
1003-3919	100" (250 cm)	\$33.00	\$115.00

STEEL RODS (each)

To join warp threads to canvas or beam sticks and
also to attach warp threads to sectional warp
beam. (each)

		Std. 5/16" dia.	Heavy 7/16" dia.	
15¾" (40 cm)	2010-4349	\$9.90		
22" (56 cm)	2020-4349	\$9.90		
24" (60 cm)	1022-4349	\$11.00		
27" (70 cm)	3030-4349	\$11.00		
36" (90 cm)	3040-4349	\$15.50	3040-4350	\$23.00
45" (115 cm)	3050-4349	\$20.00	3050-4350	\$24.00
60" (150 cm)	3060-4349	\$23.00	3060-4350	\$30.00
100" (250 cm)	1003-4349	\$33.00		

BEAM STICKS

Use this wood (W) or metal (M) beam stick in a small loom instead of using canvas

For Dorothy 15¾" (W)	2010-3920	15¾" (40 cm)	\$19.00
For Dorothy 24", Penelope & Bergere (M)	2410-3920	24" (60 cm)	\$17.00
For Compact 24" (M)	1022-3920	24" (60 cm)	\$17.00
For Artisan 36" (M)	3040-3920	36" (90 cm)	\$20.00



FLYING SHUTTLE BEATER

The flying shuttle beater is adaptable to any LECLERC loom 45" and 60" (115 and 150 cm) counter-balance models (as MIRA and FANNY), jack-type models (as NILUS, NILUS II, NILART and COLONIAL) and the new WEAVERBIRD MODEL.

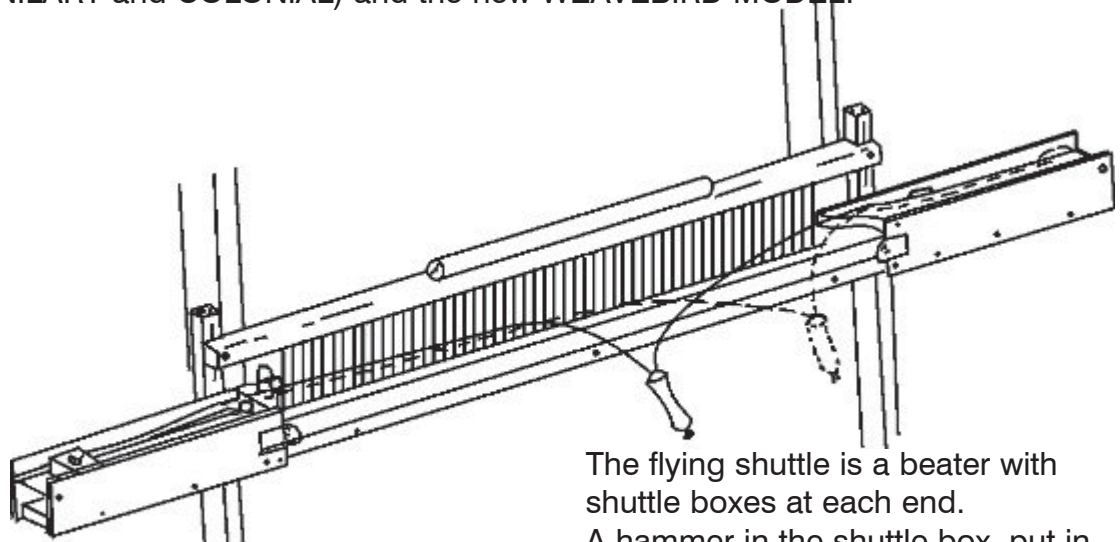

The flying shuttle is a beater with shuttle boxes at each end. A hammer in the shuttle box, put in motion by a cord and handle, strikes the shuttle, and sends it through the shed without the weaver touching it. Flying Shuttles are useful in weaving studios where long yardages are made. Time is saved in weaving wide fabrics where it is difficult to throw and catch the shuttle.

Includes one shuttle 6124-9000 and one doz of pirns 6124-7000

36"	6471-4000	1725.00
45"	6471-5000	1725.00
60"	6471-6000	1850.00
72"	6471-6072	2180.00
100"	6471-7000	2400.00

PROFESSIONAL Shuttle for Flying Shuttle Beater **6124-9000 350.00**



7" Pirns for Flying Shuttle
6124.7000 \$55.00/ 12



SHED REGULATOR



A shed regulator is an attachment for counter-balanced looms such as the Leclerc "Mira" or "Fanny". It allows a perfect shed on any tie-up. Used to regulate the height at which the shed opens for unbalanced tie-ups, such as Bronson, Waffle, Double Weave, circular weave, etc.

It allows the whole set of shafts to:

- rise when one shaft lowers and three shafts rise;
- lower when three shafts lower and one shaft rises;
- stay at the center when two shafts lower and two shafts rise.

Once installed, it can be used for both unbalanced and balanced tie-ups.

1039-0000	36	\$611.00
1040-0000	45"	\$682.00
1041-0000	60"	\$747.00

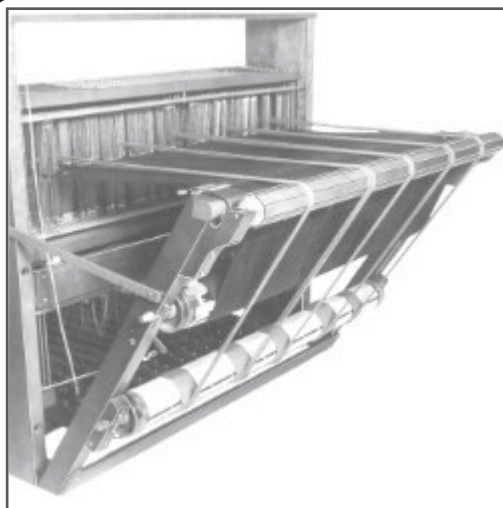

DOUBLE WARP BEAM

A useful attachment when the take-up is greater on some warp threads than on others; when using a variety of threads of different sizes and elasticity in a long warp; and for some techniques requiring two warp beams.

The extra warp beam is easy to install with brackets on the back posts of the loom. Has its own brake. The beam is removable. The extra thread beam serves to separate the warp coming from the two beams. It includes the thread beam and the brackets for mounting it.

6432-1001	Voyageur 15 ³ / ₄ "	\$475.00
6432-1000	Dorothy 15 ³ / ₄ "	\$475.00
6432-1100	Voyageur 24"	\$496.00
6432-1100	Dorothy 24"	\$496.00
1057-0000	Compact 24"	\$518.00
6431-4000	Artisat 36"	\$846.00
6432-3000	All 36"	\$846.00
6432-4000	All 45"	\$969.00
6430-6000	All 60"	\$1122.00
6432-7200	All 72"	\$1230.00

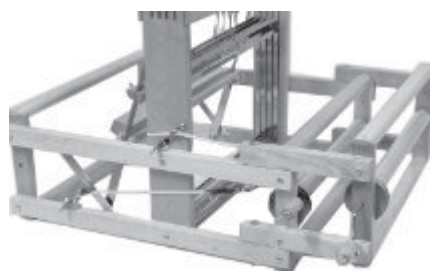

Double warp beam on a Dorothy 15¹/₂"



Leclerc Looms weighted beater

Warp Faced Weaves like Bound and Rep Weave have always presented a challenge to handweavers, especially those using wider floor looms. Rugweavers find the hard beating required to pack the weft is tiring and can cause physical strain on the weaver's wrists and arms reducing the time they can spend at the loom.

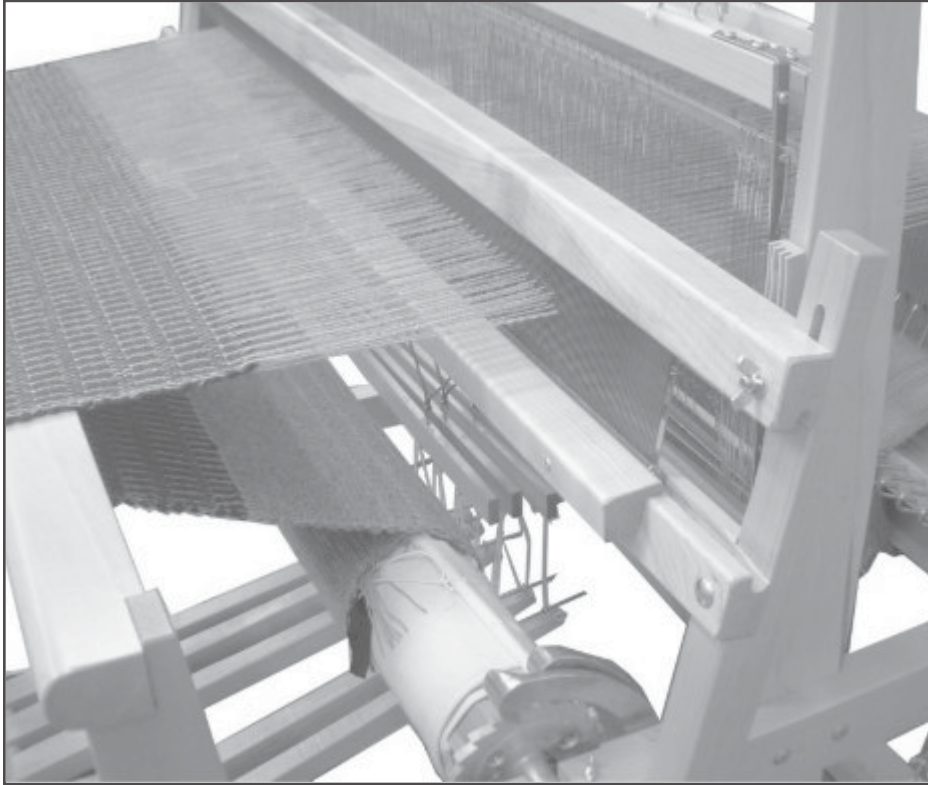

Leclerc has made Rug Weaving more enjoyable with a Weighted Beater option for its popular line of 27", 36", 45" and 60" floor looms. Identical in appearance to the standard beater mechanism shipped with the company's Nilus, Nilus II, Mira, Mira II, Fanny, Fanny II, Colonial, Colonial I and Nilart floor looms, the Weighted Beater option adds from 3 to 13 pounds (1.4 to 5.9 kgs) to the weight of the beater assembly making it easier for the weaver to beat the weft harder.

This option replaces the 2 horizontal Maple hardwood bars (battens) that hold the reed with two similar wood battens containing hidden internal weights. The weights are designed in such a way

as to not detract from the loom's appearance, damage the loom or get in the way of the weaver. Because the extra weight is distributed between the two battens, the amount of weight can be varied by using either 1 or both of the new horizontal battens.

Current loom owners can order a weighted Beater Bar upgrade kit to add this functionality to their existing Leclerc floor loom.

TOP BAR (BATTEN HANDTREE)			BOTTOM BAR WITH SHUTTLE RACE		
	WEIGHT ADDED			WEIGHT ADDED	
1560-2700 - 27" loom	3 lbs	\$178.00	1570-2700 - 27" loom	3 lbs	\$230.00
1560-3600 - 36" loom	4 lbs	\$201.00	1570-3600 - 36" loom	4 lbs	\$266.00
1560-4500 - 45" loom	5 lbs	\$228.00	1570-4500 - 45" loom	5 lbs	\$302.00
1560-6000 - 60" loom	6.5 lbs	\$285.00	1570-6000 - 60" loom	6.5 lbs	\$374.00
1560-7200 - 72"		\$382.00			

Note: Not available for the Compact and Artisat models.

REPAIR PARTS

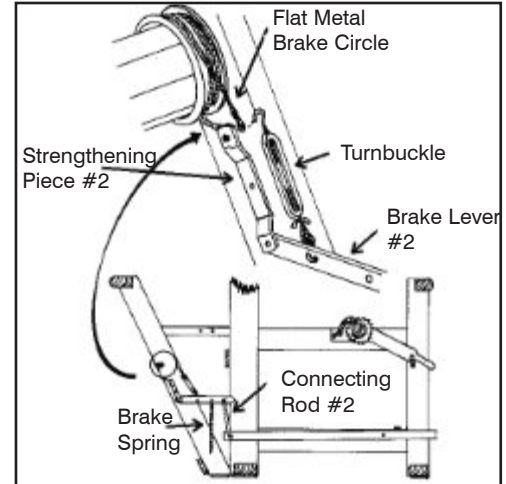
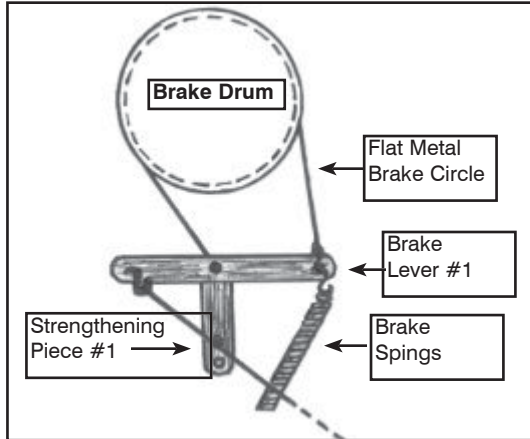

- 3000-4701 Brake circle for most looms (Artisat, Mira, Fanny, Nilus, Nilus II Colonial Nilart and Weavebird) \$40.00
- 1400-0000 Brake Circle for Old Minerva / Meco & Dorothy ... \$36.00
- 1400-0001 New brake cable Dorothy, Voyageur..... \$36.00
- 1400-0002 New brake cable Compact \$36.00
- 3000-5884 Brake spring 1/2" X 6".....\$16.00
- 4720-0000 Brake lever #1 (4").....\$10.00
- 4720-0001 Brake lever #2 (9.5").....\$22.00
- 4719-0000 Stre. piece #1\$15.00
- 4779-0000 Stre. piece #2.....\$15.00
- 4789-0000 Connecting rod#2.....\$20.00
- 5874-0000 Turnbuckle.....\$20.00
- 1113-0000 White Pulley with screw ...\$4.60

TAKE-UP MOTION WITH RATCHET PAWL:

- 1022-2802 For Compact 24".....\$56.00
- 1009-2802 For Artisat 36"\$80.00
- 3672-0000 For Mira, Fanny, Nilus and Nilus II Colonial, Nilart and Weavebird.....\$129.00
- 4170-0000 Take-up motion handle support..... \$12.00
- 3060-0000 Ratchet Pawl for take-up motion handle \$42.00
- 3070-0000 Long ratchet pawl for cloth beam.....\$52.00
- 3071-0000 Short ratchet pawl for cloth beam\$50.00
- 3080-0000 Ratchet wheel for cloth beam.....\$110.00

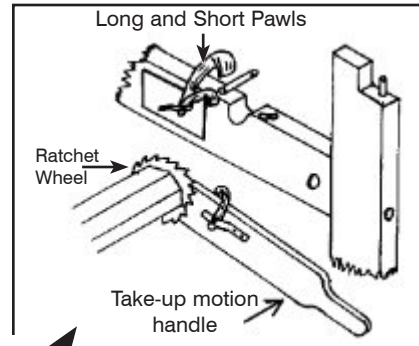

- 3000-9229 Beater Bumper (set of 2)..... \$ 8.00 each
- 3000-9233 Bumper under shaft frame 4s loom \$11.00 each
- 3000-9230 Bumper under shaft frame 8s loom \$13.00 each
- 2402-0000 Ratchet wheel Dorothy Voyageur.....\$59.00 each
- 3020-0000 Plain Wheel for front or back beam...\$89.00
- 2402-0000 Ratchet Wheel Dorothy, Voyageur.....\$60.00
- 3030-0000 Brake drum Mira, Fanny, Nilus, Nilus II, Colonial and Nilart\$240.00
- 3110-0000 Brake drum for Artisat.....\$240.00

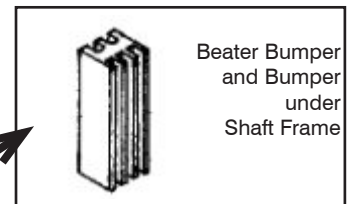

- 0342-7101 Polyvinyl non-skid base for floor looms..... \$5.75 each

The MASTER WEAVER LIBRARY is an encyclopedia with extensive information on techniques and fibers relating to handweaving.

Size: 6¾" x 9¾" (17 cm x 25 cm) **SPECIAL PRICE: \$23.00** each



VOLUME 1	0692-2100	A treasury for Beginners
VOLUME 2	0692-2200	All about Looms
VOLUME 3	0692-2300	Creative Drafting and Analyses
VOLUME 4	0692-2400	Yarns and Fibers
VOLUME 5	0692-2500	Everything a weaver should know about warps and warping
VOLUME 6	0692-2600	Technology of Handweaving (equipment and its use)
VOLUME 7	0692-2700	Contemporary Approach to Traditional Weaves: Overshot and Summer and Winter
VOLUME 8	0692-2800	Contemporary Approach to Traditional Weaves: Crackle, M's & O's and others
VOLUME 9	0692-2900	Fascination of Twills (fourshafts)
VOLUME 10	0692-3000	Fascination of Twills (Multishafts)
VOLUME 11	0692-3100	Traditional texture weaves (Waffle, Honey comb, Half-Waffle, Crepe and variations)
VOLUME 12	0692-3200	Spot weaves, old and new (Bronson, Swirl, Turned Spot Weaves, Spot Weaves and others)
VOLUME 13	0692-3300	Woven Lace and Lacey Weaves (Bronson Lace, Swedish Lace, Huckaback Lace, Cross Weaves, Net Weaves, Leno, Gauze)
VOLUME 14	0692-3400	Pile Weaves, Rugs and Tapestry
VOLUME 15	0692-3500	Double Weaves
VOLUME 16	0692-3600	Little Known Weaves Worth Knowing Better (Cannale, Locked Wefts, Lappet, Mock Leno, Paper Spots and others)
VOLUME 17	0692-3700	Resist Dyeing, Curiosities and Invention
VOLUME 18	0692-3800	Composition and Designing - Part I
VOLUME 19	0692-3900	Composition and Designing for advanced weavers - Part II
VOLUME 20	0692-4000	More about Fabrics
VOLUME 21-22	0692-4100	Thought on the weaving Craft Weaving in the past and Complete index

PATTERN DRAFTING AND TIE-UP SHEETS

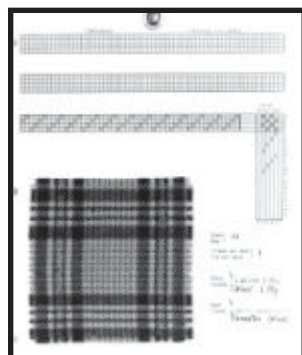

Pattern drafting and tie-up sheets for your weaving records. Made of heavy card to hold samples and all information about each pattern. Perforated to fit into a loose-leaf binder. 2 dozen per package. **One dozen has sample space on top half of sheet and one dozen on lower half, so that binder will remain flat.**

0699-0100 for 4 shaft pattern **\$6.50 / 24 sheets**
 0699-0200 for up to 12 shaft pattern **\$6.50 / 24 sheets**



WEAVING BOOKS

WARP AND WEAVE by Robert Leclerc

Instructions for table and floor, counterbalance and jack-type looms. Gives detailed instructions for warping frame, vertical warping reel, using Sectional Warp Beam and Shed Regulator (for counterbalance looms), setting up and beaming table and floor looms, tips for inexperienced weavers, threading, reading patterns, etc.

Size: 7" x 10" (18 x 25 cm) 116 pages

0692-0200 \$36.00

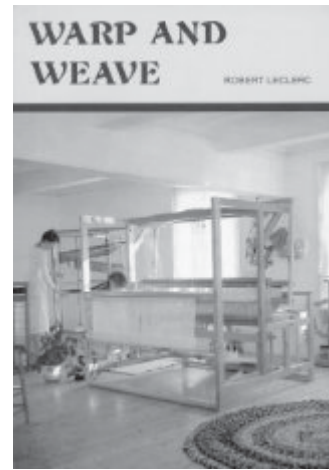

I WEAVE, YOU WEAVE Leclerc looms

Elementary Techniques for two harness weaving on a rigid heddle or lease reed. Method of preparing the thread for warping and weaving. Instructions for weaving, method of correcting broken threads and changing color, etc... Elementary instructions for tapestry weaving. Patterns are given and illustrated. Bilingual book. Size: 8½" x 11" (22 x 28 cm) 70 pages

0690-0700 \$20.00





**May we
build
one
for
you ?**

Leclerc Looms

Since 1876



P.O. Box 4, 1573 Savoie
Plessisville Qc
Canada
G6L 2Y6

Tel: 819-362-7207

Fax: 819-362-2045

e-mail: info@leclerclooms.com

Web page: www.leclerclooms.com

Your dealer:

